

TRANSPORTATION PLAN

Adopted June 3, 2013



Prepared By:
Village of Plainfield, Baxter & Woodman, Inc., and Teska Associates, Inc.

With Funding From:
Chicago Metropolitan Agency For Planning



Village of Plainfield Transportation Plan

ACKNOWLEDGEMENTS

VILLAGE BOARD

Michael P. Collins, Village President
Margie Bonuchi
Paul Fay
Bill Lamb
Garret Peck
Jim Racich
Dan Rippy

VILLAGE STAFF

Brian Murphy, Village Administrator
Allen Persons
Randy Jessen
Scott Threewitt
Michael Garrigan
Jonathan Proulx

CONSULTANTS

Baxter & Woodman, Inc.
Teska & Associates, Inc.



Village of Plainfield Transportation Plan

TABLE OF CONTENTS

Executive Summary	1
Introduction	2
Section 1	
Purpose Statement	3
Goals & Objectives of the Transportation Plan	3
Section 2: Existing Transportation System	
Master Thoroughfare Plan	5
Truck Route Plan	7
Public Transportation	8
Pace Bus Service	8
Dial-a-Ride Service	9
Metra Service	10
Section 3: Public Outreach	13
Section 4: Bicycle and Pedestrian Plan	
Bicycle Trails Plan	16
Components of the Plainfield Trail Network	16
Recommended Improvements to the Plainfield Trail Network	20
Pedestrian Access Plan	25
Components of a Complete Pedestrian Network	25
Recommended Improvements to the Plainfield Pedestrian Network	27
Implementation	35
Section 5: Roadway System & Transit Improvements	
Pavement Maintenance Plan	40
Existing Roadway Network Needs	42
Recommended Improvements to the Plainfield Roadway Network	43
Potential Public Transit Services	48
Implementation of Transit Improvements	48
Implementation of Roadway Improvements	49
Section 6: Funding Mechanisms	53
Section 7: Recommendations	58
References	60



Village of Plainfield Transportation Plan

TABLES

Number	Name	Page
2.1	Village of Plainfield Roadway Functional Classifications	6
2.2	Village of Plainfield—Metra Ridership	10
2.3	Village of Plainfield—Metra Modes of Access at Metra Stations Utilized by Plainfield Residents	10
4.1	High Priority Bicycle and Pedestrian Projects	36-37
4.2	Moderate Priority Bicycle and Pedestrian Projects	38
4.3	Long-Term Bicycle and Pedestrian Projects	39
5.1	Public Transit Needs Identified by Residents	48
5.2	High Priority Roadway Projects	50
5.3	Moderate Priority Roadway Projects	51
5.4	Long-Term Roadway Projects	52

EXHIBITS

1	Future Transportation Plan & Roadway Improvement Projects
2	Bicycle/Pedestrian & Transit Improvement Projects

APPENDIX

A	Community Remarks— www.PlainfieldTransportation.com
B	Public Meeting Materials—Handouts and Sign-in Sheets
C	Existing Transportation System
D	Existing Pavement Conditions
E	Future Land Use Plan
F	Truck Route Map
G	Federal Functional Classification Maps



Executive Summary

To prepare the Village of Plainfield for future growth and meet the challenges of traffic congestion, more work is needed. Plainfield is a rapidly growing, predominantly residential community of approximately 39,000 people located in Will and Kendall Counties. This growth, combined with the Village's close proximity to Interstate 55, and three State Routes converging through the Village's downtown core, have put a strain on Plainfield's transportation system. In addition, the Village's roadway infrastructure is aging and the need for transportation maintenance far outpaces the amount of funding available. Non-motorized forms of transportation present additional alternatives to vehicular improvements.

The purpose of this Transportation Plan is to expand upon the transportation planning work from the Village of Plainfield's *2013 Comprehensive Plan* and focus on implementing system improvements. In this Plan, the focus on transportation goes beyond vehicular traffic to include bikeways, transit, and pedestrian needs. By providing alternate means for people to travel within the community, roadway congestion can be reduced. The use of transportation planning combined with engineering for roadway improvements is a strategic effort to identify priority transportation system improvements and guide future capital expenditures.

Informational meetings were held by the Village on August 21, 2012, November 14, 2012, and March 20, 2013 to inform the public about the Village's Transportation Plan, answer questions, receive input on transportation needs, and help prioritize system improvements. Stakeholders were provided an opportunity to examine exhibits showing the proposed system improvements, take surveys, and provide feedback for consideration during the development of the Plan.

Projects in this plan range from low-cost to major capital investments. The Village of Plainfield Transportation Plan is largely unfunded. All major capital projects were evaluated and included in this study. This Plan describes the improvements recommended for roadway, bicycle and pedestrian improvements, provides associated cost estimates, and discusses potential funding mechanisms.

Approximately \$4 million per year is needed to maintain the Village's existing roadway system in its current condition; at present, about \$750,000 per year is allocated for this work. The total cost of the High Priority bicycle, pedestrian and roadway projects presented in this Plan is \$52.2 million. Constructing these improvements within the next 10 years would require a significant annual investment, in addition to yearly Village roadway maintenance costs.

The Village should consider allocating additional financial resources to fund the roadway, bicycle, and pedestrian improvements discussed in this Plan. Based on the funding made available, a new, 5-Year Capital Plan can be developed to implement the Village's vision for the future.



Village of Plainfield Transportation Plan

Introduction

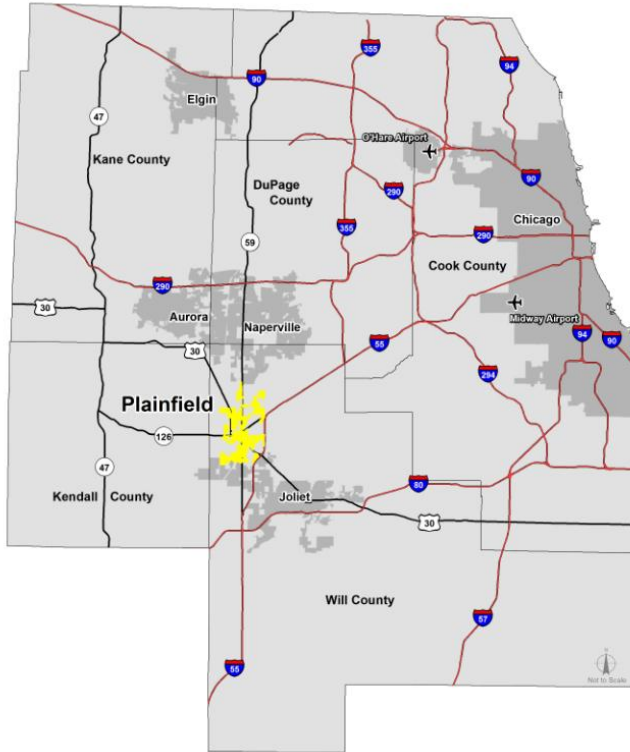

Situated on the DuPage River, the Village of Plainfield is one of the oldest communities in Will County. The Village located about 40 miles southwest of Chicago. Neighboring communities include Aurora, Oswego, Bolingbrook, Naperville, and Joliet.

The Village of Plainfield and other communities in the Will County region have grown rapidly in recent years and this growth is projected to continue. The median price of a home in Plainfield was \$265,000 in 2011 and the median household income was \$115,015. CMAP projects that the population of Plainfield will reach 82,490 and the Village will add over 9,320 jobs by 2040. Employment is focused on three main industries: manufacturing, construction, and retail trade.

Village of Plainfield Location Map

Several major roadways pass through Plainfield and Interstate 55 runs on the east side of the Village. Traffic volumes have doubled and even tripled along sections of I-55 since the mid-1980's. The Village of Plainfield's downtown core is at the convergence of three State Routes (IL 59, US 30, and IL 126). This area experiences heavy truck volumes and is highly congested. Managing this congestion is a top priority of Village residents. The existing Village transportation system has been described within the *Plainfield Comprehensive Plan*, adopted in March 2013.

This Transportation Plan also references several other planning documents in already completed by the Village of Plainfield:

- *Village of Plainfield Transportation Plan & Corridor Study*, 2006
- *Pavement Management Report*, prepared by Infrastructure Management Services (IMS), 2011
- *Plainfield Area Bicycle Plan*, 1999

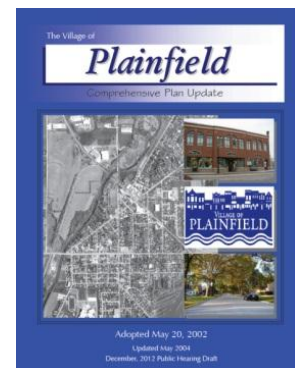



Section 1 Purpose Statement, Goals & Objectives

Purpose Statement

The purpose of this Plan is to expand upon the transportation planning work from the Village of Plainfield 2013 *Comprehensive Plan* and focus on implementing system improvements. Goals for the Village's transportation system were developed in the 2013 *Comprehensive Plan* and were used during the development of this Transportation Plan.



- The Chicago Metropolitan Agency for Planning (CMAP) provided assistance to the Village of Plainfield in the preparation of this Transportation Plan. CMAP is the official regional planning organization for the northeastern Illinois counties of Cook, DuPage, Kane, Kendall, Lake, McHenry, and Will. CMAP developed and now guides the implementation of GO TO 2040, metropolitan Chicago's first comprehensive regional plan in more than 100 years. GO TO 2040 establishes coordinated strategies that help the region's 284 communities address transportation, housing, economic development, open space, the environment, and other quality-of-life issues.

By undertaking a planning process to create a Transportation Plan, Plainfield is taking responsibility for guiding its future, and demonstrating its commitment to helping shape the future of the Chicago region as well.

Goal 1

Create a blueprint to maintain and improve the quality of the existing Village transportation system, reduce auto trips, and enhance and expand the existing transit service in the Village.

Objectives

1. Develop a prioritized list of improvements in the Village of Plainfield Transportation Plan.
 - a. Identify high, moderate, and long-term priority projects.
 - b. Include Plan improvements in the Village's 5-year Capital Improvement Plan (CIP).
2. Recommend transit improvements that can be implemented by Pace and Metra.
3. Identify resources needed to implement the projects identified in the Plan.
4. Maintain the Village of Plainfield Transportation Plan, which provides recommendations for facilities, policies, and programs to be implemented in the next 10+ years.
 - a. Update the Plan every 5 years or as necessary.
 - b. Review projects that have been completed in the Plan on an annual basis.
 - c. Develop the Plan as a guide to potential funding sources and coordinating document for other agencies and communities.



Goal 2

Develop a connected pedestrian and bicycle network that will increase bicycle trips, improve the walkability of the community, and meet the transportation and recreational needs of Village residents.

Objectives

1. Close the gaps between existing bikeway and pedestrian facilities.
 - a. Inventory the existing system.
 - b. Identify locations for improved bicycle or pedestrian facilities that will:
 - i. Close gaps between existing facilities,
 - ii. To facilitate travel between residential neighborhoods and employment, recreation, and shopping centers.
2. Work with other agencies, such as the Plainfield Consolidated School Districts, Plainfield Park District, and Will County Forest Preserve, facilitate travel between schools, parks, and other recreational areas.
3. Identify resources needed to implement the actions identified in the Plan.

Section 2 Existing Transportation System

The Village of Plainfield currently has 203 centerline miles of roadway and 16 structures on the Village System. The facilities are almost entirely 2-lane, urban roadways and bridges.

The existing transportation system was studied in great detail during the development of the Village of Plainfield's Comprehensive Plan, which was adopted in 2013.

MASTER THOROUGHFARE PLAN

The purpose of a Master Thoroughfare Plan is to create and maintain a through street system which promotes local and regional connectivity, allows for the appropriate level of access, and facilitates the movement of people and goods in an efficient manner. The Master Thoroughfare Plan identifies the functional street classifications within the Village. The classification of street impacts many aspects of the roadway design, including:

- Geometric Design (roadway width, clear zones);
- Access Control;
- Speed Limit;
- Right-of-Way Needs;
- Bicycle Accommodations;
- Lighting Standards;
- Application of traffic calming techniques;
- Landscaping;
- Parking restrictions; and
- Truck restrictions.

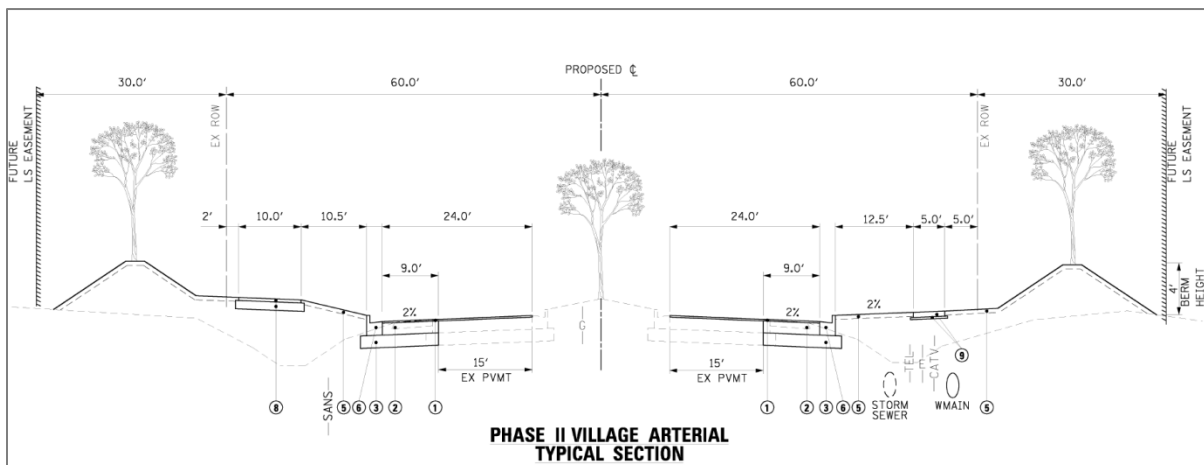

Figure 2.1 Typical Section for Plainfield Arterial Street
Arterial roadways, such as 143rd Street, are designed to accommodate higher volumes of automobile and commercial traffic. They typically have more travel lanes, stricter access control, wider rights of way, and thicker asphalt pavement.



Village of Plainfield Transportation Plan

The recommended roadway Functional Classification System was developed as part of the 2006 *Transportation Plan and Corridor Study* and 2013 *Comprehensive Plan* and the existing roadways are classified accordingly:

Table 2.1 Village of Plainfield Roadway Functional Classifications

Interstate Route		Strategic Regional Arterial Routes	
Interstate 55		IL Route 59	
		119 th Street	
		Caton Farm Road	
		WIKADUKE Trail (Ridge Road)	
Major Arterials		Minor Arterials	
US Route 30		111 th Street	
IL Route 126		127 th Street	
143 rd Street		Renwick Road	
		County Line Road	
Major Collectors		Minor Collectors	
Drauden/Steiner/Heggs Road		Eastern Avenue	
Van Dyke Road (north of Lockport St)		River Road	
Plainfield/Naperville Road		Old Indian Boundary Road	
248 th Street		I-55 Frontage Road	
Book Road		Fort Beggs Street	
Essington Road		Van Dyke Road (south of Lockport St)	
135 th Street		Fraser Road	
Lockport Street		Lily Cache Road	
Walker Road		Howard Street	
Normantown Road		Fritz Road	
		Rolf Road	
		Meadow Lane	



TRUCK ROUTE PLAN

The Chicago metropolitan area is considered the freight center of North America. By 2040, the Chicago Metropolitan Agency for Planning (CMAP) projects freight volumes (by weight) to increase by 60 percent. Truck movements are also expected to increase their volume of freight carried by 70 percent. This growth will continue to place a strain on the Village's infrastructure, including delays at railroad crossings, noise, pollution, and traffic congestion caused by trucks. In addition, the amount of truck traffic has a dramatic effect on pavement deterioration—one loaded truck can have the same impact as 4,000 passenger cars.

Designating truck routes helps assure that trucks travel on roadways designed to handle heavier loads and that noise impacts to residents are minimized. The efficient movement of goods and delivery of services is crucial to the economic well-being of the Village of Plainfield.

The State has a Designated State Truck Route System for roadways in Illinois:

- Class I Facility: limited access divided highways (Interstate 55)
- Class II Facility: non-interstate roadways approved for all load widths of 8 foot 6 inches or less and a wheel base no greater than 55 feet (US Route 30, IL Route 59, and IL Route 126)



IL Route 126 (Main Street) at IL Route 59

Trucks accelerate at a slower rate than other vehicles and can contribute to traffic congestion.

The Village of Plainfield's downtown core is at the convergence of three State Routes (IL 59, US 30, and IL 126). This area experiences heavy truck volumes and is highly congested. Managing this congestion is a top priority of Village residents. The recommended Truck Routes for the Village of Plainfield were developed as part of the *2013 Comprehensive Plan* and are shown in Appendix F. Also shown on the Truck Route Map are the existing and future commercial and industrial land use areas, which will serve as the major generators of truck activity. The planned Village truck routes will be able to access the major commercial and industrial areas of Plainfield without having to travel through the downtown core. This will result in less congestion in this area as desired by Village residents. Future truck routes include:

- Interstate 55, IL Route 59, IL Route 126, 143rd Street, 119th Street and Caton Farm Road.
- The future WIKADUKE Trail
- The future segments of the I-55 frontage roads between 135th Street and US Route 30.

PUBLIC TRANSPORTATION

Pace Bus Service

There are presently two Pace suburban routes serving the Plainfield Community:

Route 755-Provides weekday rush hour and midday service between the Plainfield Park-n-Ride (adjacent to the Village Hall), the Illinois Medical District, and Union Station in the West Loop, with intermediate stops along I-55 at the Pace Park-n-Ride in Bolingbrook, the CTA Pink Line Damen Station and UIC.



Route 855-Provides weekday rush hour and midday service between the Plainfield Park-n-Ride (adjacent to the Village Hall) and the Chicago Loop, with intermediate stops along I-55 at the Park-n-Ride at Spartans's Square in Romeoville, the Pace Park-n-Ride at Old Chicago in Bolingbrook, the Pace Park-n-Ride at Canterbury in Bolingbrook, the Pace Park-n-Ride in Burr Ridge and in Chicago at various stops on Clark St., Monroe St. and Michigan Ave.

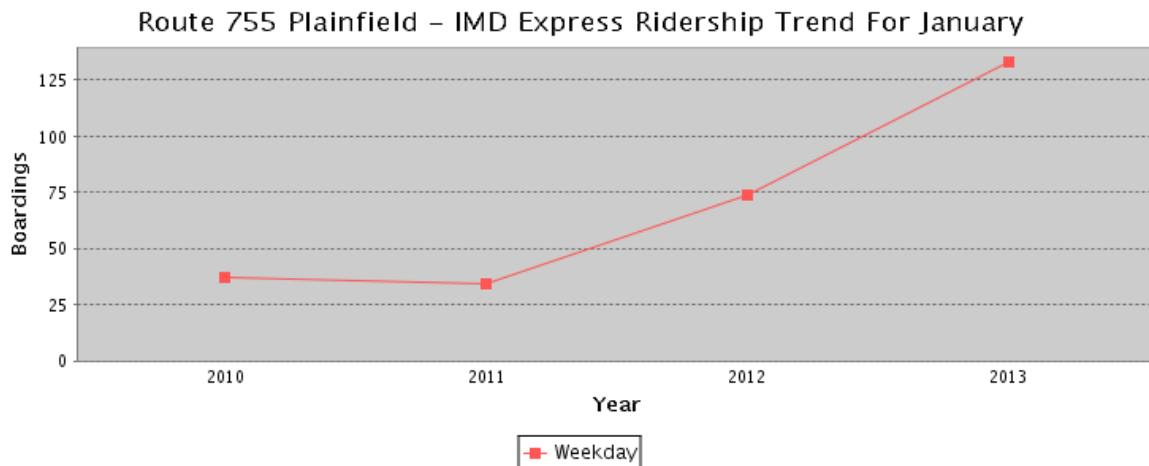

Figure 2.2 Pace Route 755 Ridership Trend
Pace's Route 755—Ridership increased dramatically after the I-55 shoulder-riding program was introduced in 2011.

Pace Routes 755 and 855 can operate on sections of the shoulders of I-55. Under the program, only Pace buses are permitted to use designated sections of the I-55 shoulder when traffic in the regular lanes is flowing at less than 30 miles per hour. Buses using the shoulder cannot travel at speeds greater than 35 mph, or 15 mph faster than the flow of traffic in the regular lanes - whichever is less. Special signage and roadway markings indicate where buses can use the shoulder, and the bus has special markings indicating it is authorized to use the shoulder.

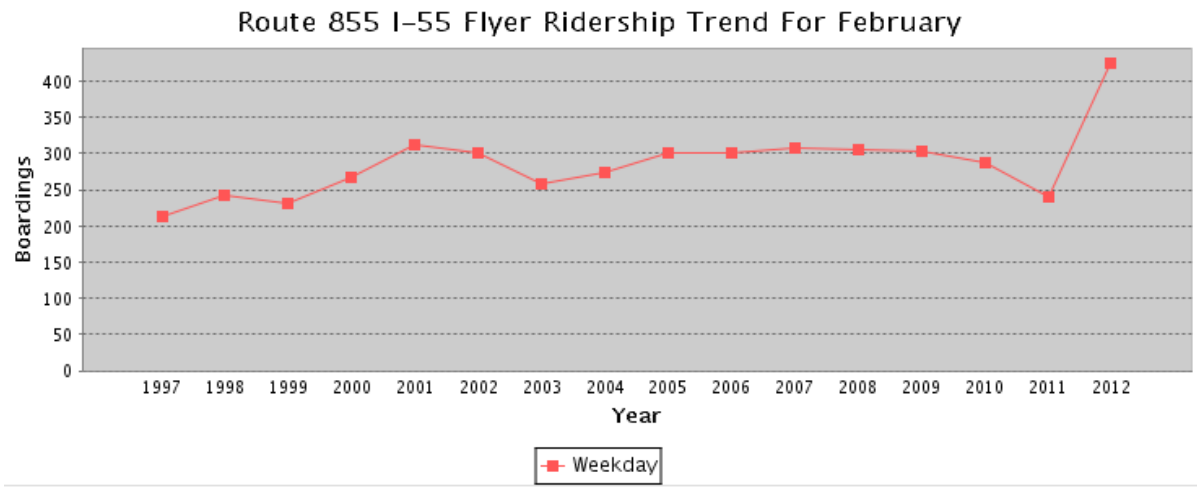

Figure 2.3 Pace Route 855 Ridership Trend
Pace plans to add more trips on Routes 755 and 855 in May of 2013 because of growing ridership

Since Pace’s Bus on Shoulder Program began in 2011, ridership on Route 755 and 855 have increased dramatically as passengers take advantage of faster, more reliable service between the southwest suburbs and Chicago. In May of 2013, Pace will expand and modify service on the I-55 corridor to provide more rush hour trips, some service later in the evening, and midday trips.

Free parking for Routes 755 and 855 is offered at the Plainfield Park-n-Ride, located on Village Center Drive, near the Village Hall, and on Van Dyke Road. Plainfield recently worked with Pace on adding additional on-street Park-n-Ride spaces in response to increased ridership. In the long term, Pace and the Village may need to work together to provide a more permanent, off-street parking facility in response to the increased demand on Routes 755 and 855.

Dial-a-Ride Service

Plainfield is also served by Pace’s Dial-a-Ride Service, providing transportation to residents who are unable to drive. Dial-a-Ride programs have certain rules for fares, geographic boundaries, and passenger eligibility.

This non-fixed route (paratransit) service utilizes vans and small buses to provide pre-arranged trips to and from specific locations within the service area. Individuals wishing to use the Dial-a-Ride Service must be deemed eligible based on local requirements, typically seniors or people with disabilities. The service operates Monday through Friday, 6:00am to 5:00pm. The areas currently served include the City of Joliet, Homer Township, Jackson Township, Joliet Township, Lockport Township, Plainfield Township, Wheatland Township and Troy Township.





Village of Plainfield Transportation Plan

Metra Service

There is no Metra commuter rail service in Plainfield. There are three Metra lines in nearby Naperville and Joliet with four stations that are regularly utilized by Plainfield residents:

1. Lockport Station— Heritage Corridor (HC)
2. Joliet Station—Rock Island District (RID) and Heritage Corridor (HC)
3. Route 59 Station—Burlington Northern Sante Fe (BNSF)
4. Naperville Station—Burlington Northern Sante Fe (BNSF)

Based on Metra’s 2006-Origin-Destination Survey data, it appears that the largest portion of Plainfield residents access the Route 59 Metra station in Naperville. Boarding for Plainfield riders along each of the lines are shown below:

Table 2.2 Village of Plainfield—Metra Ridership

Station Name	Number of Plainfield Residents Boarding Train on Average Weekday	Percent of Total Riders at Station
Lockport	76	14%
Joliet	137	12%
Route 59	521	9%
Naperville	41	1%

Source: Metra, 2006 Origin-Destination Survey

Metra collects data on the origins of its passengers and their mode of access to rail stations and the data for the Stations used by Plainfield residents is summarized in Table 2.3 below:

Table 2.3 Modes of Access at Metra Stations Utilized by Plainfield Residents

Station	Walk	Bike	Drive Alone	Carpool Driver	Carpool Pass.	Dropped Off	Taxi	Bus	Metra	Other
Lockport	2.1%	0%	75.5%	5.2%	5.2%	11.3%	0%	0.3%	0%	
Joliet	4.8%	0.1%	66.6%	2.2%	2.9%	18.5%	0.1%	2.6%	0%	2%
Route 59	6%	0%	71%	3%	3%	12%	0%	4%	0%	0%
Naperville	9%	2%	44%	2%	3%	21%	1%	18%	0%	1%

Source: Metra, 2006 Origin-Destination Survey

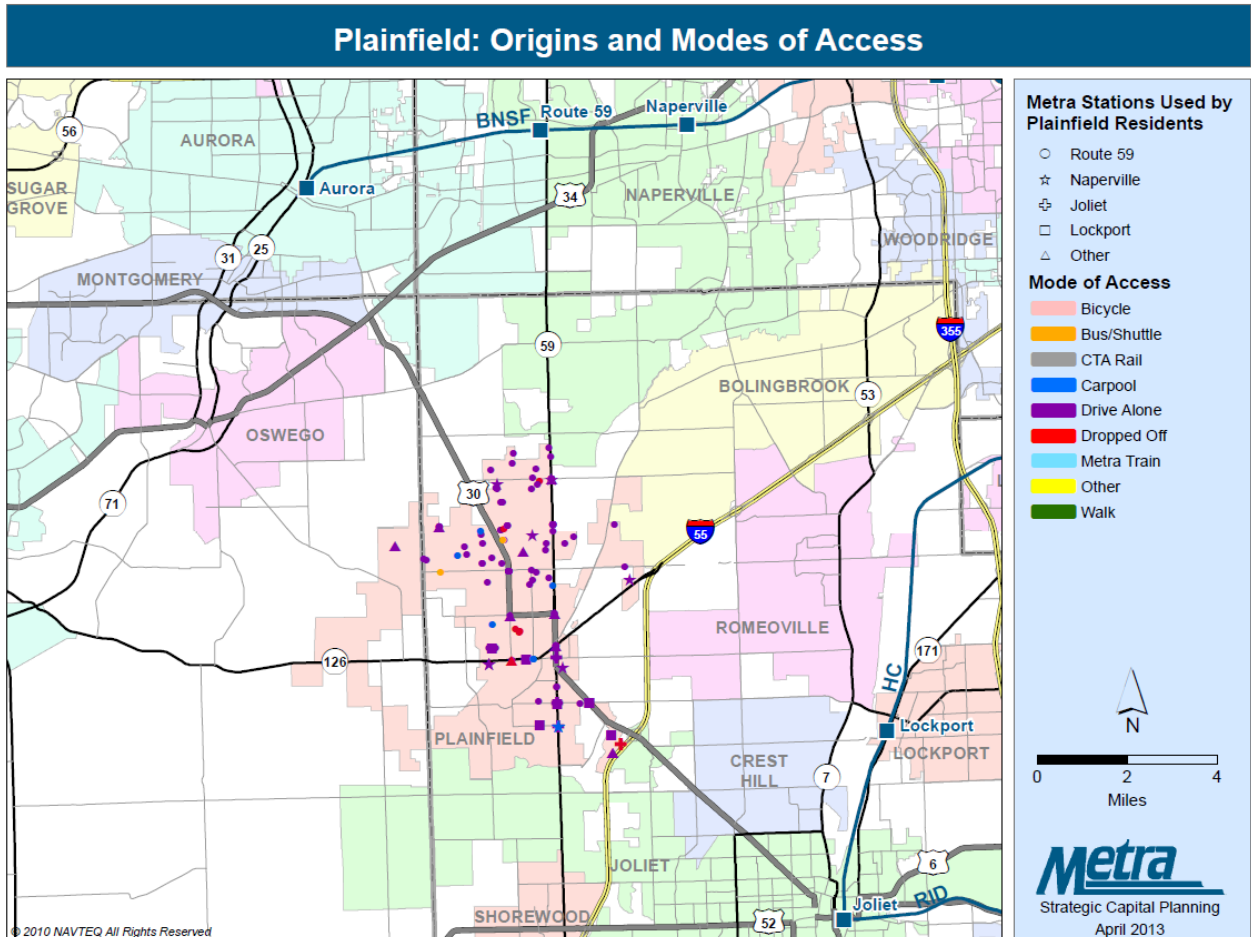

Figure 2.5 Metra Origins and Modes of Access

Metra's studies show that most Plainfield residents access the Route 59 Station in Naperville.

Source: Metra. Division of Strategic Capital Planning. April 2013

As part of its Long Term Vision, Metra is studying a 55-mile Suburban Transit Access Route, or STAR Line. The map on the following page illustrates that this suburb-to-suburb commuter rail service would extend from the Joliet area to O'Hare Airport. There are two proposed STAR line stations within the Village of Plainfield (Van Dyke Road and Renwick Road). The Village has adopted Transit Oriented Plans (TOD) for both potential station areas. Unfortunately, funding has not yet been secured for the STAR Line and no clear timeline is available for implementation. The development of this additional transit service will occur beyond the planning horizon of this Transportation Plan.



Figure 2.5 Proposed Metra STAR Line
 Future STAR Line Stations are on Van Dyke Road and Renwick
 Road within the Village of Plainfield

Source: STAR Line Alternatives Analysis, July 2012

Section 3 Public Outreach

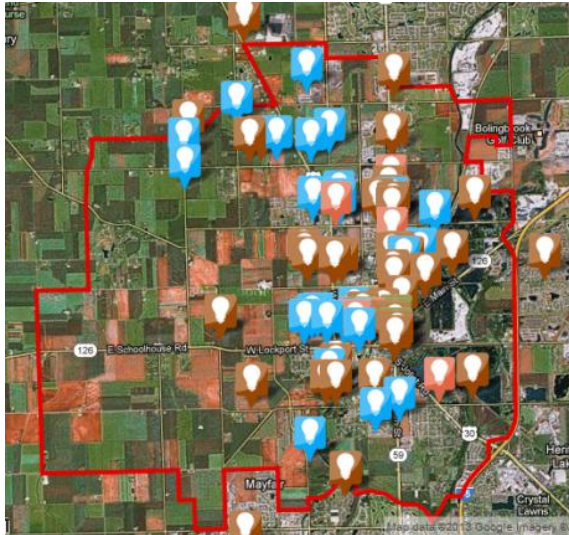

Figure 3.1 Public Comment Map
Nearly 100 comments were placed on the project website about improving traffic in Plainfield. The Village Planning Boundary is shown as the red line in the illustration above.

To assist with the development of this Transportation Plan, an extensive community outreach program was created and tailored specifically to help the Village get valuable feedback from stakeholders. A project website was established so residents could share their feedback on how to improve transportation within the Village, along with concerns and questions, at <http://www.plainfieldtransportation.com/>.

Nearly 100 comments were left on the site, which also allowed residents to share photos and pinpoint the sites they feel should take priority. Several articles were written in the Plainfield Patch and project information was posted in the Villages E-News updates, Twitter account, and Village Voice newsletter. The

project team also met and/or coordinated with many local agencies, including Kendall County Highway Department, Plainfield Park District, Plainfield Police Department, Plainfield Fire Protection District, Plainfield School District, and the Will County Forest Preserve.

First Public Meeting

The first public outreach event was held on August 21, 2012 at Cruise Night downtown. The goal for the meeting was to build awareness about the project—with the classic cars lining the streets in the downtown core, the event's large attendance engaged many people to participate in the planning process. Business cards were developed with the project website, QR code, and Village Contact information, and were distributed to many attendees at the event. A booth was set up on Lockport



Street and stakeholders were provided an opportunity to examine exhibits showing the existing roadway, bicycle and pedestrian network, and to provide feedback that could be taken into consideration during the development of the Plan. The booth also had raffle for a local restaurant gift card and for a collection of Matchbox cars. To be eligible for the raffle, participants were asked to provide comment on transportation within the Village. Specifically,



participants were asked:

- To identify gaps in existing conditions data;
- Identify deficiencies in the existing system (capacity, signage, safety, etc); and
- Suggest improvements to roadways and local trail networks.

Approximately twenty written comments were received, which were posted on the comment page of the project website. Utilizing the comments provided at the public meeting and on the project website, a list of roadway, transit, bicycle and pedestrian improvements was developed to improve transportation within the Village of Plainfield.

Second Public Meeting



The second public meeting was held on November 14, 2012. The purpose of the meeting was to present an overview of the proposed roadway, transit, bicycle and pedestrian improvements and obtain public input on prioritizing them. There was a short presentation of the data collection and the work performed to date, followed by a facilitated question and answer session. An update on the next steps for the project was also provided. Prior to and following the presentation the Project Team was available to discuss the

study with stakeholders.



November 4, 2012 Public Meeting

Visitors examined the proposed transportation projects and provided feedback about priority.

In addition to the public meeting, surveys were posted on the project website. These results helped prioritize the list of transportation projects. Utilizing the comments provided at the public meetings and on the project website, the list of transportation improvement projects was prioritized.

ON-LINE SURVEY RESULTS

Rank the transportation improvements below in order of importance, listing the most important project #1 and the least important as #6.

1. *Extend 143rd Street from IL 59 to IL 126.*
2. *Improve access to the Lockport Metra Station and increase frequency of Heritage Corridor Service.*
3. *Complete sidewalks near existing schools.*
4. *Intersection improvements at IL 59 at 135th Street to improve traffic flow.*
5. *Provide additional Pace Bus service along IL 59 and/or to downtown Joliet.*
6. *Provide pedestrian connections from subdivisions to surrounding amenities (e.g. retail, school, recreation).*

Figure 3.2 On-line survey results



Village of Plainfield Transportation Plan

Third Public Meeting

The third public meeting was held on March 20, 2013. The purpose of the meeting was to obtain feedback on the Draft Transportation Plan. There was also a brief presentation, giving an overview of the proposed roadway, transit, bicycle and pedestrian improvements, followed by a facilitated question and answer session. An update on the next steps for the project was also provided.

Copies of the handouts and sign-in sheets from the public informational meetings are included in the Appendix. Suggested transportation improvements and survey results from the website are also contained in Appendix B.



Village Board Meetings

The Transportation Plan was also discussed at the July 16, 2012, September 10, 2012, December 10, 2012 and January 28, 2013 Village Board Meetings. A brief presentation was given about the status of the Plan at each meeting and Board members were given an opportunity to ask questions and provide feedback on the Transportation Plan.



Section 4 Bicycle and Pedestrian Trails Plan

BICYCLE TRAILS PLAN

In an effort to link residential areas with key community facilities like parks, schools, commercial centers and employment, the *Plainfield Area Bicycle Plan* was developed in 1999. However, given the non-linear development of sub-divisions, the trail network outlined in this plan has many gaps. Bicycle and Pedestrian Access goals in this Plan are to bridge these gaps, increase ridership and enhance bicycle rider and pedestrian safety through best practices and design. This plan summarizes the gaps in the existing trail network, suggests options to close these gaps, and outlines ways to implement and finance opportunities to increase usage and safety.

The overall Bicycle and Trails Plan is illustrated on Exhibit 2. This plan is an updated and more detailed version of the earlier 1999 plan noted above. It is based on a review of existing and proposed regional trail networks, and discussions with the Will County Forest Preserve District, Plainfield Park District, and Village departments. Significant resident input also went into the development of the plan, both from the web-based community mapping tool, online survey and in-person input at community events and meetings.

Bicycle trails and pedestrian access are two distinct issues. The *bicycle trail system* is a network of shared-use or multi-use paths (off-road paths that a minimum of 8' wide), bike lanes (dedicated lanes on a roadway) and bicycle-friendly streets (streets with speed limits less than 30MPH) used for commuting and recreation by bicyclists and pedestrians alike. Pedestrian access via a network of sidewalks on the other hand, while providing the same connectivity, is distinct from the trail network as bicycle riding on a typical 4' or 5' sidewalk can create significant conflicts with pedestrians. Given this distinction, the gaps and recommendations for each of these two networks have been analyzed individually as the Bicycle Trails Plan and Pedestrian Access Plan.

Each of these sections highlights gaps in the network and recommends improvements and best practices to increase the safety of users and increase overall ridership.

COMPONENTS OF THE PLAINFIELD TRAIL NETWORK

The trail network in Plainfield has the potential to connect users to parks, community amenities, schools, regional and local trails, and commercial areas from their neighborhoods. However, issues like incomplete sections along the trail that force riders on to busy streets, missing crosswalks, and other bikeway design flaws not only reduce the safety of the users, but also discourage cautious bikers. Improvements are needed to complete the trail system so that it truly works as a safe and healthy form of recreation and transportation for users of all ages. This section covers the main components of a trail system and addresses the existing gaps in Plainfield's trail network. The trail network is comprised of several components. The descriptions on the following pages should be used to guide the construction of all future trail components identified in Exhibit 2.



Shared-use paths

These are off-road bikeways or trails which are typically within the right-of-way. In Plainfield, they are typically 10' wide and accommodate pedestrians, joggers, bicyclists and all other non-motorized users.

Figure 4.1
Example of a Shared-use Path in Plainfield

On-street bike lanes



Figure 4.2 Bike Lane Example
Bike lanes are designated for the exclusive use of bicyclists

Source: www.pedbikeimages.org/ Dan Burden

Where shared-use paths are not yet constructed or not feasible, connections to the trail network are provided by dedicated bicycle lanes along the roadway. A bike lane is that portion of a roadway that has been designated for preferential or exclusive use by bicyclists. Bike lanes provide a dedicated travel lane within the street. Bicyclists travel one-way with the flow of traffic. The minimum width of a bike lane varies based on the roadway cross section, and are generally a minimum of 5' wide. For curbed streets without parking, bike lanes must be at least 4 feet wide (not including gutter pan) on each side of the road with longitudinal pavement markings, bike lane symbols, and Bike Lane signage.

Most conflicts between bicycles and motorists occur at intersections and driveways. Good intersection design is important to clearly indicate to bicyclist and motorists how they should travel through the intersections.

Buffered bike lanes are slowly replacing the simple bike lanes as it increase the safety of the bicyclist and hence encourages more people to ride their bikes. A buffered bike lane simply has a painted buffer between the bike lane and the adjacent travel lane or the adjacent parking lane when located along the curb. This buffer reduces the chances of a biker being injured due to dooring (contact due to opening of a car door into a biker's path of travel). The down side of providing a buffer is that it eats into the road right-of-way and reduces the overall width available for travel lanes and other roadway areas.



Figure 4.3 Example of a Buffered Bike Lane between the travel lane and bike lane

Source: www.bikewalkincolnpark.com

Shared Roadway

Bicycles may be operated on all roadways except where prohibited by statute or regulation. Most streets within the Village of Plainfield are shared roadways. On a shared roadway, bicyclists and motorists share the same travel lanes without a striped separation. Shared roadways can legally be used by bicyclists, regardless of whether the facility is specifically designated as a bikeway. Shared roadways include:

- Roads and streets with no bicycle provisions.
- Wide outside/curb lanes
- Roadway shoulders
- Designated bicycle routes



Figure 4.4
Example of a Shared Roadway
Source: www.marinbike.org

Paved shoulders

Paved shoulders can accommodate bicycle travel efficiently and provide additional benefits to the roadway:

- Shoulders can be used by stopped vehicles or emergency vehicles,
- Shoulders provide added safety to motorists, and
- Paved shoulders provide lateral support for the pavement.

The shoulders along rural roads (which have speed limits less than 45 MPH) can typically be used by bicyclists if they are paved and wide enough. The typical widths of paved shoulders for bicycle use ranges from 4' to 8'.

The table on the following page lists the minimum recommended widths for shoulders, lanes and paths based on the type of roadway and posted speeds from IDOT's Bureau of Design and Environment Manual.



Figure 4.5
Paving the entire shoulder on this segment of Plainfield- Naperville Rd will encourage more bicycle travel
Source: www.communityremarks.com Heath



Figure 4.6
Curbs protruding into the shoulder push bicyclists into the travel lane (Shown here at Ridge Road and Grand Park Boulevard)
Source: www.communityremarks.com Heath



Roadway Characteristics	Bicycle Accommodation Required			
	Paved Shoulders (inclusive of rumble strip)	Outside Curb-lane Width	Bicycle Lane (includes gutter pan)	Side Path Bidirectional
Rural Roadways < 30 mph Posted				
Design Year ADT under 2000	None			
Design Year ADT 2000 – 8000	4 ft (1.2 m)			optional
Design Year ADT > 8000	4 ft (1.2 m)			optional
Rural Roadways 30 – 35 mph Posted				
Design Year ADT under 2000	4 ft (1.2 m)			optional
Design Year ADT 2000 – 8000	4 ft (1.2 m)			optional
Design Year ADT > 8000	6 ft (1.8 m)			optional
Rural Roadways 36 – 44 mph Posted				
Design Year ADT under 2000	6 ft (1.8 m)			optional
Design Year ADT 2000 – 8000	6 ft (1.8 m)			optional
Design Year ADT > 8000	6 ft (1.8 m)			optional
Rural Roadways > 44 mph Posted				
Design Year ADT under 2000	6 ft (1.8 m)			optional
Design Year ADT 2000 – 8000	8 ft (2.4 m)			optional
Design Year ADT >8000				10–12 ft (3.0 m – 3.6 m)
Urban Roadways < 30 mph Posted				
Design Year ADT under 2000		None		optional
Design Year ADT 2000 – 8000		13 ft – 14 ft (4.0 m – 4.3 m)		optional
Design Year ADT > 8000			5 ft (1.5 m)	optional
Design Year ADT > 15,000			optional 6 ft (1.8 m)	10–12 ft (3.0 m – 3.6 m)
Urban Roadways 30 - 35 mph Posted				
Design Year ADT under 2000			5 ft (1.5 m)	optional
Design Year ADT 2000 – 8000			5 ft (1.5 m)	optional
Design Year > 8000			6 ft (1.8 m)	optional
Design Year ADT > 15,000			optional 6 ft (1.8 m)	10–12 ft (3.0 m – 3.6 m)
Urban Roadways 36 - 44 mph Posted				
Design Year ADT under 2000			5 ft (1.5 m)	optional
Design Year ADT 2000 – 8000			6 ft (1.8 m)	optional
Design Year ADT > 8000				10–12 ft (3.0 m – 3.6 m)
Design Year ADT > 15,000				10–12 ft (3.0 m – 3.6 m)
Urban Roadways > 44 mph Posted				
Design Year ADT under 2000			6 ft (1.8 m)	optional
Design Year ADT 2000 – 8000			6 ft (1.8 m)	optional
Design Year ADT > 8000				10–12 ft (3.0 m – 3.6 m)
Design Year ADT > 15,000				10–12 ft (3.0 m – 3.6 m)

BICYCLE FACILITY SELECTION

Figure 4.7 IDOT’s Facility Selection Criteria
Bicycle facilities are selected based on the roadway type (rural or urban), speed limit, right of way availability, and traffic volumes.

Source: IDOT’s Bureau of Design & Environment Manual, Figure 17-2.A

RECOMMENDED IMPROVEMENTS TO THE PLAINFIELD TRAIL NETWORK



Gaps along the shared-use paths- Existing shared-use paths in Plainfield were typically constructed during the development of each parcel. This has created sections of the path that are disconnected due to undeveloped parcels. At such locations, the path abruptly stops at the parcel boundary. If an adjacent parcel is undeveloped at the time of construction of the pathway, a temporary paved connection should be made to the road with lane markings of the road connecting it to the next shared-use path location (provided the roadway is sufficiently wide to accommodate bike use per the preceding section).

Figure 4.8 Shared Use Path Gap
The adjacent picture shows one such location along Van Dyke Road where a shared-use path on the west side of the road abruptly ends.

Connections across rivers and creeks- The DuPage River and smaller creeks within Plainfield currently create breaks in the trail system because the trails do not continue across the existing bridges. Pedestrian bridges are needed at such locations along the proposed trails.

Connection to regional trails- The DuPage River Trail is an important regional trail within the planning area. It is planned to run continuously from Naperville to the I&M Canal Trail in Channahon. Completion of this trail is a goal of the Plainfield Park District. The trail will run through the heart of the Village, connecting downtown with surrounding neighborhoods and recreational amenities like Mather Woods, Settler's Park and Eaton Preserve. Many sections along this trail are currently incomplete. The Park District has been actively seeking grants to assist in trail completion. While outside the planning area, future connections of the trail network to the surrounding trail systems of Will and Kendall County are recognized and indicated on the trails map (Exhibit 6).

Future Connections - The *Illinois Highway Code* (605 ILCS 5/4-220 new) states that bicycle and pedestrian ways shall be given full consideration in the planning and development of transportation facilities, including the incorporation of such ways into State plans and programs. Portions of several State highways have been designated as a bikeway in this Plan. As the State moves forward to improve IL 126, IL 59, and US 30, the Village must work with the IDOT to review each project and determine if it is eligible for consideration of bicycle and pedestrian accommodations.

Different jurisdictions in charge of the trail sections- The trail system within the Plainfield planning area includes the Plainfield Park District, Will County Forest Preserve and Kendall County. Coordination will be needed between these agencies to make sure that the trail network is seamless.

Bike lanes along minor collector roads- For the trail connections along Meadow Lane, Indian Boundary Road, Lily Cache Road and other low traffic streets marked on Exhibit 6, connections can be provided in the form of on-street bike lanes. These should be well signed to guide bikers along the trail network.

Bicycle Parking Facilities

Providing safe and durable racks to secure bicycles is important for schools, parks, libraries and all commercial areas. The racks should be located in visible, well lit and well signed areas close to the building entrance (within 100'). For temporary parking facilities, the racks should be able to support the bicycles at two points. For long-term parking facilities such as at the Pace bus stop at Village Hall covered parking should be provided to protect the bikes from the elements.



Figure 4.9 Bicycle Parking

Sharrows for shared lanes

A sharrow is a symbol marked within a travel lane on the pavement and consists of a bicycle with two chevron markings above it. It indicates that the lane is shared by both vehicles and bicycles, and warns the motorist to watch out for bicyclists. As Lockport Street in the Downtown Area does not have the space for a separate bike lane, marking the travel lane in each direction with sharrows immediately after an intersection and spaced at intervals not greater than 250 feet thereafter is recommended. In addition, signage along the roadway (like the one in the image below) with a sharrow and the words 'Share the Road' will also help educate drivers about sharrows.



Figure 4.10 Sharrows

Sharrows indicate where bicyclists should travel along the roadway. They also reduce potential conflicts with opening car doors.

Curb and storm grate details

The Village currently uses storm-grates that have bars parallel to the direction of travel and located within potential bike lanes. These grates are hazardous for bicyclists because bike tires can get stuck in them. Existing streets within the Village can be retrofitted by replacing standard drainage grates with a design that is compatible with bicycle use. This will improve mobility and comfort for bicyclists and reduce bicycle-related crashes.

R-3246-AM
Combination Inlet Frame, Grate, Mountable Curb Box

Heavy Duty

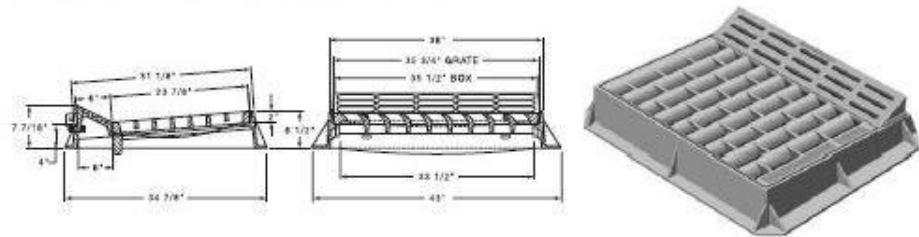

Figure 4.11 Bicycle Compatible Drainage Grates
Bicycle compatible drainage grates, like the one shown above, make shared lanes more compatible with bicycling.

Source: Neenah Foundry

Crosswalks- Currently, busy streets like Route 59 do not have accommodations for trail connections across the intersections (119th, 127th, 135th, etc.). The trails need to be continued to the curb of the cross street with special crosswalk signals for trail users. The signal request button should be conveniently located for use by bikers.

Railroad crossing improvements – Given the orientation of the railway lines in Plainfield, all the locations at which the shared-use path cross the railroad tracks are at acute angles. This is dangerous to bicyclists because it has the potential of trapping the bicycle’s front wheel in the rail flange-way resulting in a loss of steering control. This issue can be addressed by widening the outside lane, shoulder, or bicycle lane to improve the angle of approach. Alternately, compressible flange-way fillers can also be used to fill the gaps between the asphalt and flange, but would need to be checked for replacement periodically. The top surface of the shared-use path and railway tracks should be level so that it is easier for the bicyclist to maneuver over them safely. The Village has secured a grant to help improve with the 135th Street railroad crossing in such a manner.



Figure 4.12 The angular railroad crossing along Van Dyke Road

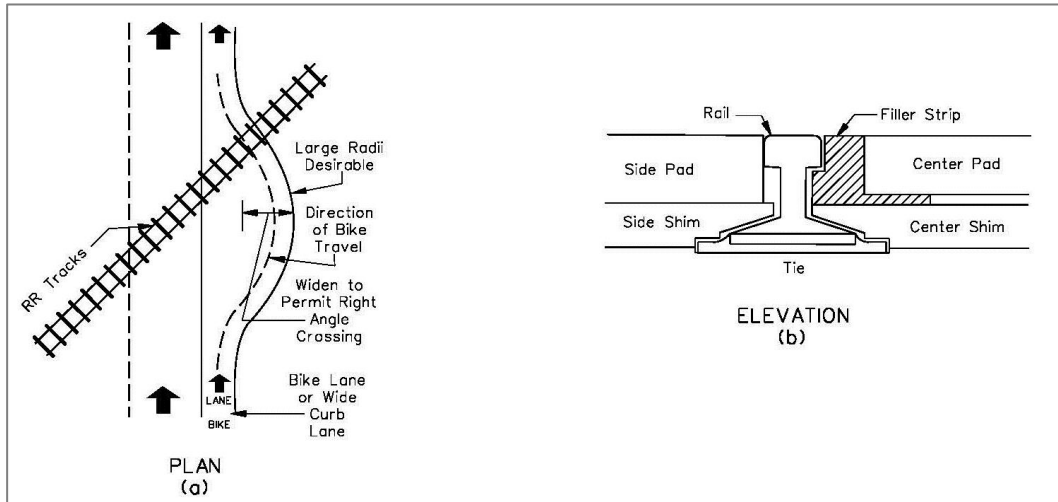

Figure 4.13 Example of a Bike Lane Crossing a Railroad

In this IDOT illustration:

- a – Indicates the widening of a bike lane to improve the angle of approach
- b – Compressible flangeway fillers used to smooth the transition over the rail.

Source: IDOT's Bureau of Design & Environment Manual, Figure 17-2.R

Bikeways along shoulders - For bikeway network connections along roads that have wide shoulders; the shoulders should be paved for at least 6' beyond the outer lane marking. This will allow for bikers to ride on the shoulder even along rural roadways.

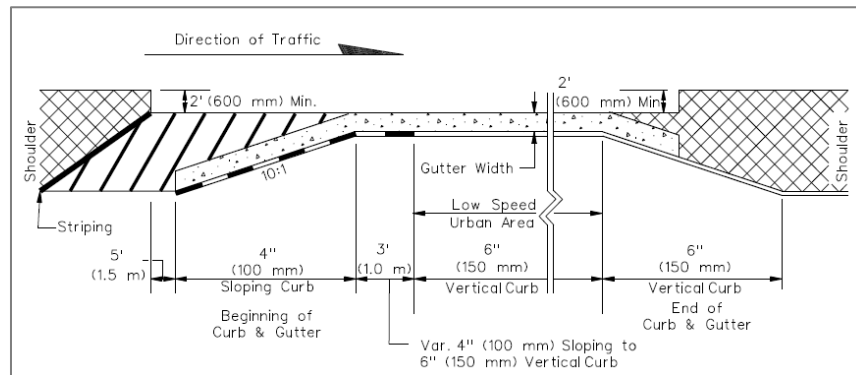

Figure 4.14 Example of a Paved Shoulder Transition into a Curbed Section

In this IDOT illustration, a wider curb provides bicyclists with more room to travel safely along the edge of the roadway.

Source: IDOT's Bureau of Design & Environment Manual, Figure 17-2.B

It is also important to ensure that the shoulder width is maintained at intersections, and that apron areas beyond the shoulders are paved to prevent gravel from spilling onto the shoulder. For areas like bridges where a sufficient shoulder width cannot be maintained, part of the travel lane should be striped to accommodate the bikers (illustrated in the figure that follows).

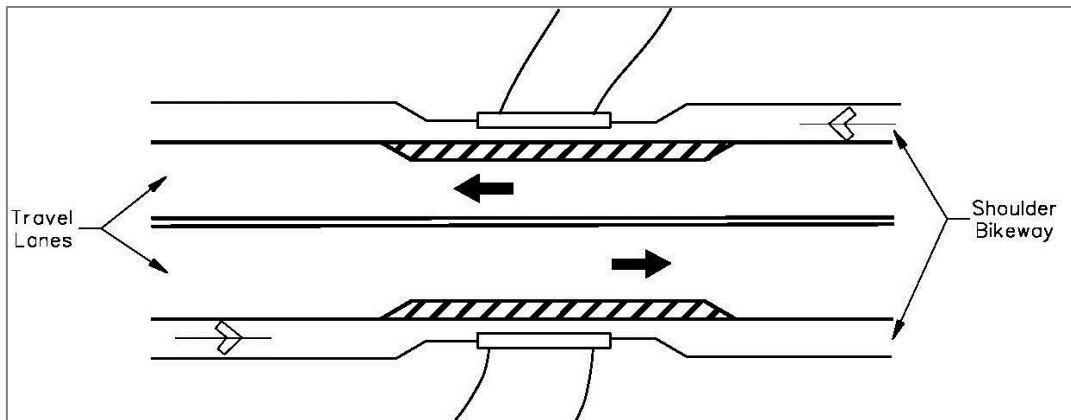

Figure 4.15 Example of a Striping for Unavoidable Obstacles

In this IDOT illustration, areas where the shoulder needs to be reduced considerably should be compensated by the provision of a striped area within the adjacent travel lane.

Source: IDOT's Bureau of Design & Environment Manual, Figure 17-2.S

Lighting

Appropriate lighting of shared-use paths where biking at night is expected (e.g.: Connections to the downtown area, recreation facilities and commercial areas along Route 59). The lighting should be scaled to pedestrian or bicycle path users and should be vandal proof where security is an issue. Sections of the riverwalk and the DuPage River Trail near downtown are areas where such lighting would be appropriate.



Figure 4.16 Shared Use Path Lighting

The Village's Riverwalk Committee supports lighting shared use paths near Plainfield's downtown core.



PEDESTRIAN ACCESS PLAN

Similar to the trail network, the network of sidewalks in Plainfield has the potential to connect users to parks, community amenities, commercial areas, and to schools within their neighborhoods. Incomplete sections of sidewalks, missing pedestrian crosswalk signals, lack of access to adjacent amenities or commercial areas and lack of universal design (described in the section below) discourage walking. The two important deciding factors in the choice between driving and walking is the perceived ease of access (based on the points mentioned above) and the travel time. The time it takes to get into a car, drive to a location within a half mile distance and park, is nearly the same as walking the same distance, provided that the route is accessible for pedestrians. Hence, locating neighborhood amenities, shops, elementary and middle schools within this half-mile walking distance of residents would encourage them to walk rather than drive. The sections that follow cover the aspects of complete streets needed to encourage walking, and highlight specific areas in Plainfield that need to be improved.

Exhibit 2 and Tables 4.1 thru 4.3 show the location and list the priority sidewalk installation projects. Projects were prioritized based on public and staff input, project readiness, potential for receiving matching funds, cost, and feasibility. High priority projects are those that can be built within a 5-year time frame. Moderate priority projects are those that can be built within the next 5 to 10 years and most do not have guaranteed funding sources. Long term considerations are those that are anticipated to be constructed beyond the 10 year period, require significant funding, and most involve right of way acquisition.

COMPONENTS OF A COMPLETE PEDESTRIAN NETWORK

The descriptions below should be used to guide the development of sidewalks and access to amenities within the Plainfield Planning Area.

Complete the gaps in the sidewalk network

Providing a complete network of sidewalks in Plainfield has the potential to connect users to parks, community amenities, commercial areas, and to schools within their neighborhoods. Installing sections of missing sidewalks and pedestrian crosswalk signals will encourage walking to adjacent amenities or commercial areas.

Encouraging safe routes to schools

Site plan design that gives school children the ability to reach school building entrances without crossing bus zones, parking entrances, and student drop-off areas is vital to their safe passage. This issue is becoming increasingly important as limited funding for schools is causing budget cuts in all areas, but particularly in transportation. In many cases children that were once bussed across busy streets are now required to walk to school. Many times, parents concerned for their children's safety will drive them relatively short distances to school aggravating already congested areas.

Traffic calming measures near schools like on-street parking, street trees, narrower streets, marked crosswalks, controlled intersections and caution signs help make motorists more aware while driving near schools and in turn are more likely to watch out for children crossing the street.

Education and support for walking and biking – Educating students and their parents about the benefits of walking and biking to school, provision of sufficient bike storage facilities at each school, and workshops on bike maintenance are all important steps to increase the use of non-motorized options to access schools.

Trees and plantings along the sidewalk provide the comfort of shade for pedestrians, besides other environmental benefits. They also have a traffic calming effect resulting from the perceived narrowing of the roadway. When planted between the sidewalk and the roadway, they also form a buffer between the traffic and pedestrians, thus increasing their perception of safety. Most of the sub-divisions in

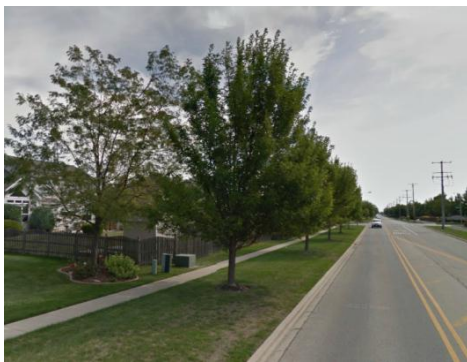

Figure 4.17
Shaded, buffered sidewalk

Plainfield currently have such a buffer between the roadway and sidewalk, and improving areas that are missing sidewalks in a similar fashion is recommended. However, tree branches must be consistently pruned to avoid conflicts with bikers (pruned to maintain a minimum 7' clearance).

Visibility at intersections: The plantings must be sufficiently set back from both street and driveway intersections to maintain visibility for both bike riders and motorists.

Complete Streets – Adopt a complete streets policy to accommodate users of all age groups and abilities to access the pedestrian and trails network via non-motorized options.



Curb treatments – Use colored tactile tile strips at the curbs before crosswalks, to warn pedestrians about the change in surface type.

Figure 4.18
Detectable Warnings
Source: philly.com



Village of Plainfield Transportation Plan

Signage at pedestrian crosswalks – Signage for pedestrians and motorists is encouraged to increase the safety of the pedestrians, especially at busy intersections like those along Route 59.

Parking lots in commercial areas should have accommodations for pedestrian access from sidewalks and shared-use paths in the area. Signage should also be provided where driveways and sidewalks intersect so that drivers look out for pedestrians before crossing the sidewalk.

Signage, visibility and safety – The use of marked crosswalks, controlled intersections, caution signs, pedestrian crossing islands, bump-outs, mini-roundabouts, etc. will help calm traffic in pedestrian areas and make it safer for pedestrians. Lockport Street from IL 59 to IL 126 in the downtown core is an excellent example of this.

Railroad crossings – The sidewalks at railroad crossings are missing at most locations in Plainfield, except at Lockport Street. Completing these as per details outlined in the previous section is important for the safe passage of pedestrians across the tracks.

RECOMMENDED IMPROVEMENTS TO THE PLAINFIELD PEDESTRIAN NETWORK

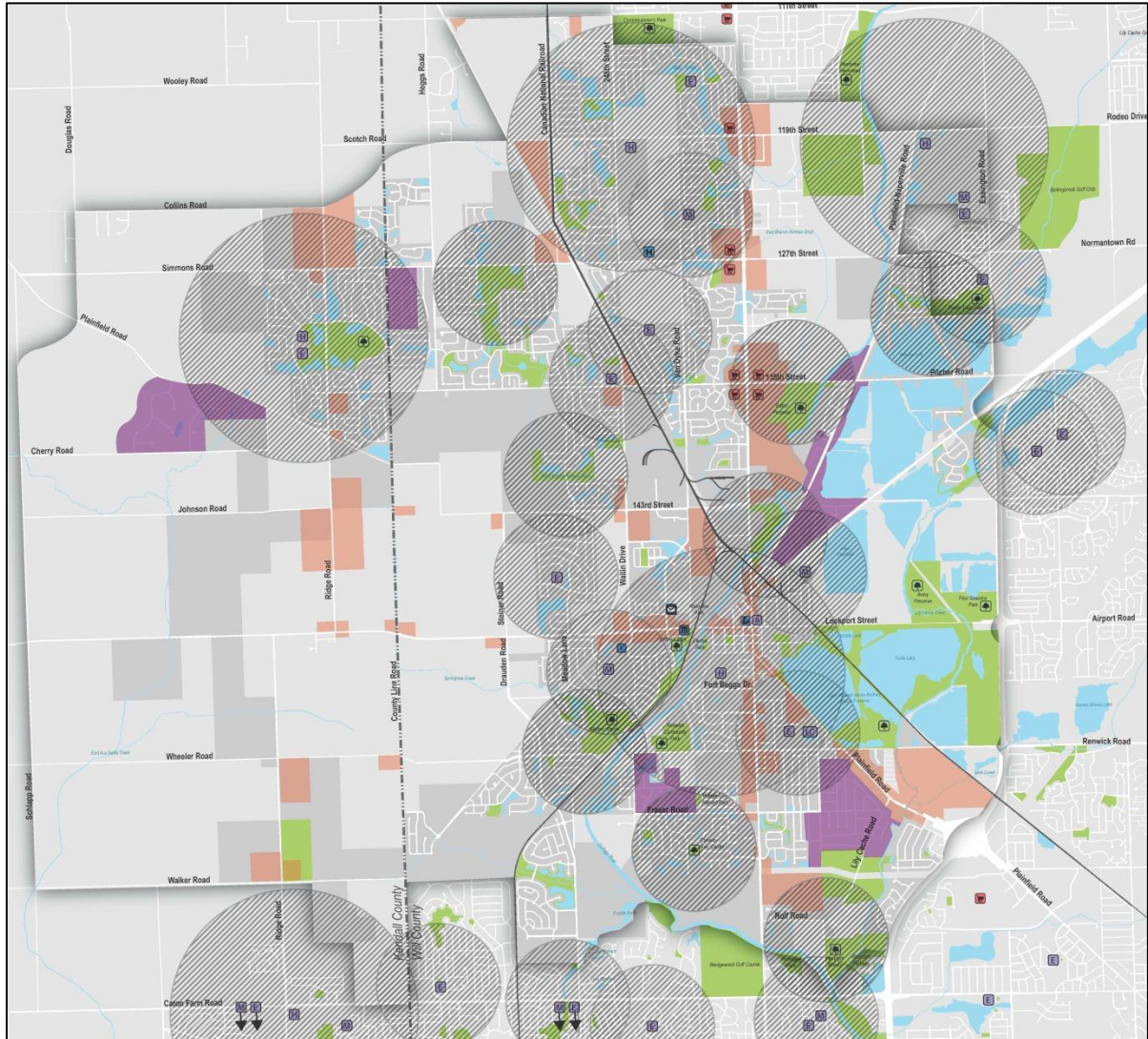

Figure 4.19
Location of Community Amenities in Plainfield

This map shows the location of schools, libraries, recreation facilities, existing and future commercial areas (marked in red color) and pockets of unincorporated areas that currently lack sidewalks (marked in purple). The circles on the map indicate areas of a ½ mile distance around elementary and middle schools and 1 mile distance around high schools that are considered walkable from the surrounding neighborhoods. Ensuring that all these areas are well connected via a system of sidewalks encourages walkability.

Some of the overall recommendations to improve walkability are listed below. A complete listing of the prioritized projects is included in Tables 4.1, 4.2 and 4.3.

1. The Grande Park subdivision has a middle school, elementary school and park amenities. While the sidewalks within the Village are complete, the unincorporated subdivisions of Wheatland Plains and the area south of Plainfield Road lack sidewalks. Completing these would make them more accessible to the neighborhood schools and park.

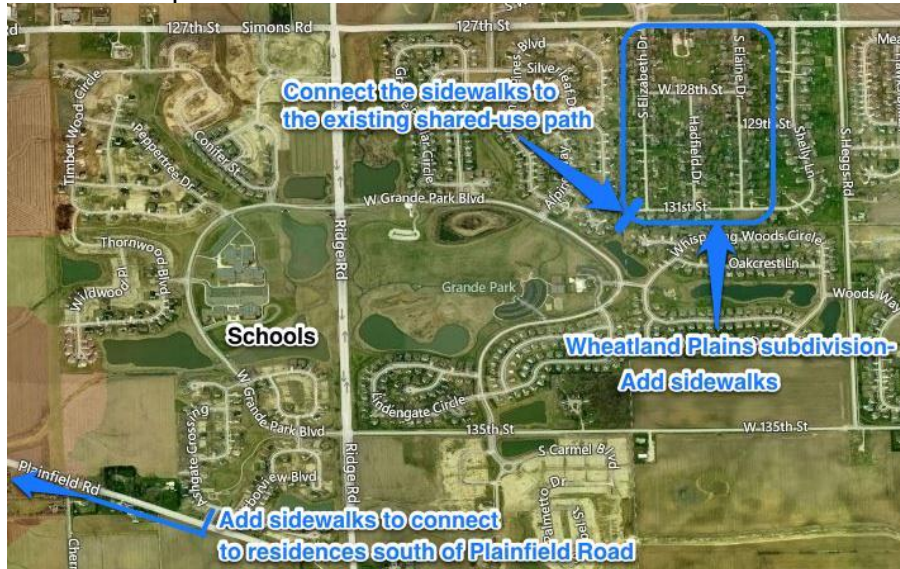

Figure 4.20

2. A section of the sidewalk on the east side of 248th Street between 119th Street and 127th Street has not yet been constructed. Completion of this sidewalk is imperative for pedestrian access to Plainfield North High School.

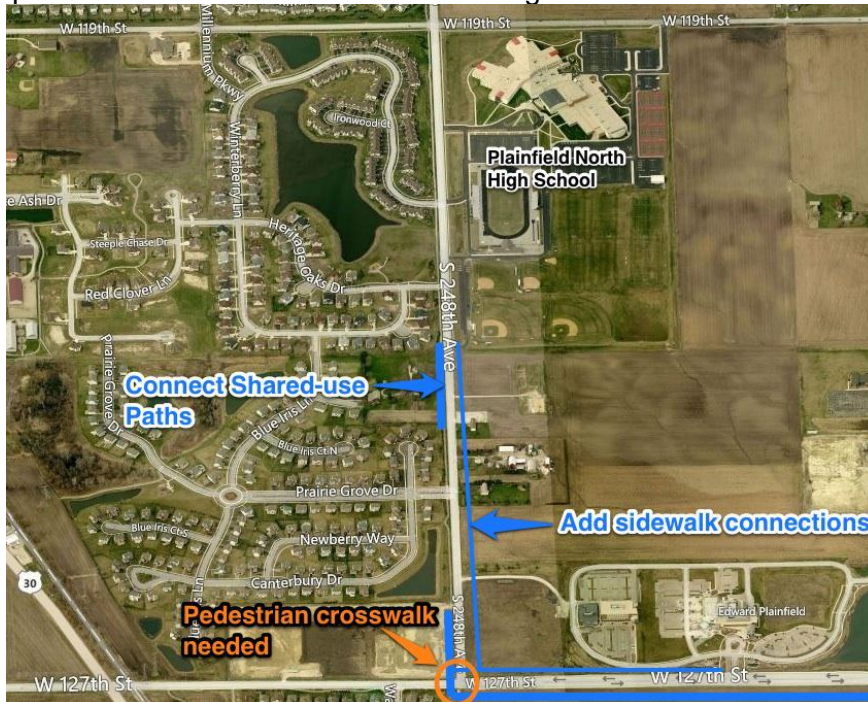

Figure 4.21

- The intersections along Route 59 at 119th, 127th and 135th Streets currently lack pedestrian crosswalk signals as well as crosswalk striping. Implementing these improvements will increase the access for residents to the commercial uses along Route 59.

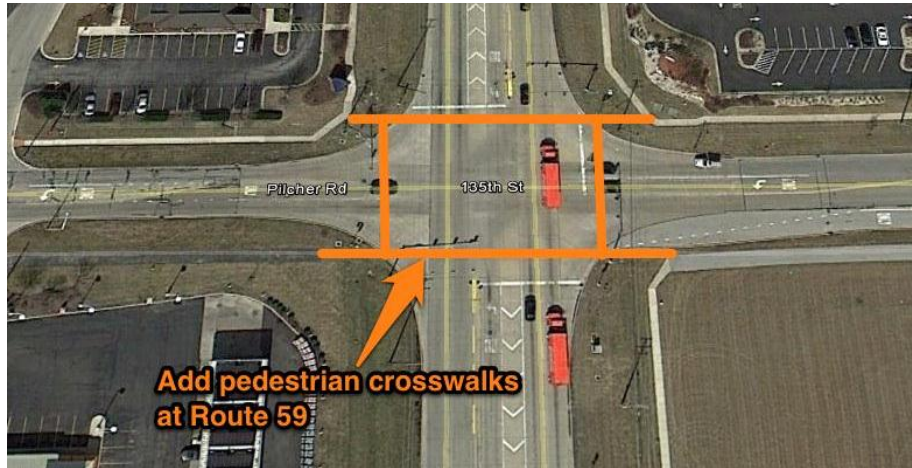

Figure 4.22

- In addition, cut-through sidewalk connections from Champion Creek, Heritage Meadows, Kensington Club, Riverview Estates and Golden Meadows Estates to Il 59 will allow the residents quicker access to the commercial areas without having to first get to Van Dyke Road and then head toward Route 59.

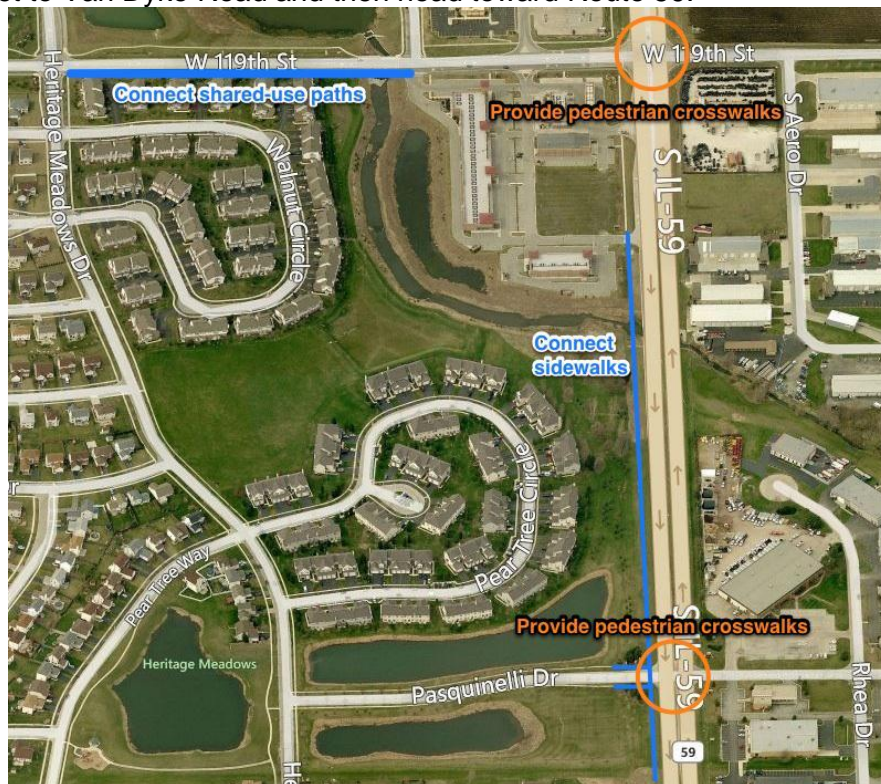

Figure 4.23



Figure 4.24

5. A large percentage of unincorporated areas are currently without sidewalks (shown in purple on the map on Page 28). Connecting the residential areas between Plainfield-Naperville Road and IL 126 with sidewalks is important to increase their access to downtown. Sidewalks are also missing along Center Street near Indian Trail School, on the south sides of Renwick Road near Central Elementary School, on the south side of Fort Beggs Drive, and along the east side of Van Dyke Road from the Post Office to Lockport Street. Adding sidewalks to these areas will increase the access for residents to important amenities within the downtown area.



Figure 4.25



Figure 4.26



Figure 4.27



Figure 4.28

6. Pedestrian crosswalks and signals are also needed across Lockport Street at Meadow Lane, Wallin Drive and Van Dyke Road, as well as at Route 59 and Plainfield Road. These crosswalks are vital for access to the schools in the neighborhood. The addition of a crosswalk and signal for pedestrians at Route 59 and Fraser Road will increase the resident's access to parks and amenities along Fraser Road.

During the development of this Plan, the Village received many comments about pedestrian and bicyclist's safety concerns along Pilcher Road/135th Street in front of the Lakelands Club. Traffic volumes and vehicle speeds are high due to the direct access that 135th Street provides to the Interstate 55 Highway. There are significant Right of Way and environmental constraints along this corridor that would accompany a project to provide a new sidewalk on 135th Street. A more logical bicycle/pedestrian connection can be made internally within the subdivision and should be pursued by the Village.

Overall, a complete pedestrian network will encourage walkability in Plainfield especially in the downtown area.



IMPLEMENTATION OF BICYCLE AND PEDESTRIAN IMPROVEMENTS

The overall Bicycle and Trails Plan is illustrated on Exhibit 2 and specific projects are shown in Tables 4.1, 4.2, and 4.3. Significant resident input also went into the development of the plan, both from the web-based community mapping tool, online survey and in-person input at community events and meetings. Projects were prioritized based on public Village Board, and staff input, project readiness, potential for receiving matching funds, cost, and feasibility. High priority projects are those that can be completed within a 5-year time frame. Moderate priority projects are those that can be completed within the next 5 to 10 years. Long term considerations are those that are anticipated to be constructed beyond the 10 year period, require significant funding, and usually involve right of way acquisition. Most Moderate and Long Term projects do not have guaranteed funding sources.

A simple and cost-effective way to integrate non-motorized users into the design and operation of the transportation system is to include bicycle and pedestrian accommodation as an incidental part of larger ongoing projects. Examples include:

- Providing paved shoulders on new and reconstructed roads.
- Restriping roads (either as a stand-alone project or after a resurfacing or reconstruction project) to create a wider outside lane, Sharrows, or striped bike lanes.
- Building sidewalks and trails, and marking crosswalks or on-street bike lanes as a part of a roadway improvement.

Many of the bicycle and pedestrian projects in this Plan may be incorporated into a larger capital improvement by the Village. These projects are cross-referenced in each Table.

A cost analysis was performed for the Short-Term and Moderate considerations with a base cost in 2013 dollars. Segments were analyzed between major intersections and a cost analysis was provided for each segment. Major cost items include right of way acquisition, construction of the hot-mix asphalt pavement, sidewalk and bicycle path construction, earthwork, storm sewers, removal and disposal of unsuitable soils and materials (assuming poor soil quality), and roadway lighting. Intersection improvements included the following: traffic signal modification or installation, transitional intersection lighting, reconstruction of the pavement of the intersecting street to provide auxiliary lanes, and right of way acquisition. Items estimated as a percentage of total construction cost included maintenance of traffic, contractor mobilization, erosion control, relocation of utilities, contingency, and engineering required to design and construct the improvements.



HIGH PRIORITY BICYCLE AND PEDESTRIAN PROJECTS (0 TO 5 YRS)

TABLE 4.1

Project Number	Action	Purpose	Participants	Preliminary Estimate of Cost	Possible Funding Sources *	Corresponding Roadway Project Number
1	Construct shared use path on 248 th Street from 119 th Street to 127 th Street	Eliminate gaps	Plainfield	\$214,000	MFT, STP, TAP, CMAQ	
2	Construct shared use path on Van Dyke Road from 135 th Street to 119 th Street	Expand bicycle network	Plainfield	\$1,178,000	MFT, STP, TAP, CMAQ	
3	Construct shared use path on Plainfield-Naperville Road from 119 th Street to existing trail south of 127 th Street	Expand bicycle network	Plainfield	\$1,006,000	MFT, STP, TAP, CMAQ	6
4	Construct shared use path on 127 th Street from Van Dyke Road west to 252 nd Street	Eliminate gaps	Plainfield	\$613,000	MFT, STP, TAP, CMAQ	
5	Construct shared use path on 127 th Street from IL 59 east to Essington Road	Expand bicycle network	Plainfield	\$2,146,000	MFT, STP, TAP, CMAQ	6,45
6	Construct shared use path on 135 th Street from Ridge Road to Meadow Lane	Eliminate gaps	Plainfield	\$1,555,000	MFT, STP, TAP, CMAQ	
7	Construct shared use path on 143 rd Street from Meadow Lane to Van Dyke Road	Expand bicycle network	Plainfield	\$664,000	MFT, STP, TAP, CMAQ	43
9	Construct shared use path from Settler's Park to Mather Woods	Eliminate gaps	Plainfield	\$211,000	MFT, TAP	
10	Construct shared use path connection across the DuPage River at old Renwick Road	Expand bicycle network	Plainfield Plainfield Township	\$830,000	MFT, TAP	32
11	Construct shared use path continuation along Drauden Road, south of Caton Farm Road (<i>with City of Joliet</i>)	Eliminate gaps	Plainfield, Joliet	\$1,279,000	MFT, STP, TAP, CMAQ	
12	Construct shared use path continuation along Caton Farm Road from Ridge Road to Caton Ridge Dr/Fresno Lane (<i>City of Joliet</i>)	Eliminate gaps	Joliet	\$1,030,000	MFT, TAP	
15	Improve signage to Riverview Park	Improve ingress/egress to park	Plainfield	\$1,100	MFT, TAP	
18	Construct shared use path connection along 127 th Street between Northwest Community Park and Tuttle Estates Subdivision (Gilmore Rd)	Eliminate gaps	Plainfield	\$1,546,000	MFT, TAP	
19	Install pedestrian signals and crosswalks at Meadow Lane & IL 126	Improve intersection safety for bicyclists and pedestrians	Plainfield, IDOT	\$115,000	MFT, STP, TAP, CMAQ	11
20	Install pedestrian signals and crosswalks at Wallin Drive & IL 126	Improve pedestrian access	Plainfield	\$117,000	MFT, STP, TAP, CMAQ	35,42
21	Install pedestrian signals and crosswalks at Van Dyke Road & IL 126	Improve pedestrian access	Plainfield	\$114,000	MFT, STP, TAP, CMAQ	35
22	Construct new sidewalk, Install pedestrian signals and marked crosswalks at IL 59 & 127 th Street	Improve pedestrian access	Plainfield	\$127,700	MFT, TAP	
24	Install pedestrian signals and crosswalks at IL 59 & Fraser Road	Improve pedestrian access	Plainfield	\$224,500	MFT, STP, TAP, CMAQ	

Note: Project Number is for location reference only; it does not indicate priority ranking

*See next page for Legend



HIGH PRIORITY BICYCLE AND PEDESTRIAN PROJECTS (0 TO 5 YRS) (CONTINUED)
TABLE 4.1 (CONTINUED)

Project Number	Action	Purpose	Participants	Preliminary Estimate of Cost	Possible Funding Sources*	Corresponding Roadway Project Number
25	Install sidewalk, pedestrian signals and marked crosswalks at the intersection of IL 59 & 119 th Street	Eliminate gaps and improve pedestrian access	Plainfield	\$116,200	MFT, STP, TAP, CMAQ	3
26	Add roadway signage at the Fort Beggs Trail & Renwick Road	To increase visibility of crossing	Plainfield	\$1,700	MFT, TAP	32
29	Extend shared use path across the CN railroad on 135 th Street	Increase safety for users crossing the railroad tracks	Plainfield, CN, ICC	\$305,000	MFT, ICC	
38	Install sharrows in select subdivisions (30mph speed limit or less)	Increase safety for bicyclists sharing the road with motorists	Plainfield	\$1,000 to \$133,000	MFT, TAP	
39	Construct sidewalk connecting to Lockport Street Post office	Eliminate gaps	Plainfield	\$80,000	MFT, TAP	
40	Add sidewalk on Center Street near Indian Trail School	Provide connection to Indian Trail school	Plainfield	\$146,000	MFT, TAP	
41	Construct new sidewalk on Renwick Road from Arbor Drive to Howard Street	Provide connection to Central Elementary School	Plainfield	\$54,200	MFT, TAP	47
43	Construct new sidewalk on Fort Beggs Drive from James Street to IL 59.	To eliminate gaps and improve connectivity to Plainfield Central High School	Plainfield	\$149,000	MFT, TAP	
52	Install new sidewalk, pedestrian signals and marked crosswalks at IL 59 & 135 th Street	Eliminate gaps and improve pedestrian access	Plainfield	\$228,700	MFT, TAP	4
53	Construct missing sidewalk on Main Street between IL 59 and Lockport Street	Eliminate gaps and improve pedestrian access	Plainfield, IDOT	\$97,000	MFT, TAP	35

Note: Project Number is for location reference only; it does not indicate priority ranking

*Project Funding Legend

MFT = Motor Fuel Tax (State)
 Surface Transportation Program (Federal)
 TAP= Transportation Alternatives Program (Federal)
 ICC = Illinois Commerce Commission (State)
 CMAQ = Congestion, Mitigation, & Air Quality Improvement Program (Federal)



MODERATE PRIORITY BICYCLE AND PEDESTRIAN PROJECTS (5 TO 10 YRS)
TABLE 4.2

Project Number	Action	Purpose	Participants	Preliminary Estimate of Cost	Possible Funding Sources*	Corresponding Roadway Project Number
8	Construct shared use path on IL 126 from Meadow Lane to Van Dyke Road	Improve access to downtown core	Plainfield	\$728,000	MFT, CMAQ, TAP, STP	42
14	Construct shared use path to DuPage River	Complete DuPage River Trail Connection	Park District	By Park District, \$798,000		
16	Construct shared use path on IL 59 from IL 126 to Fraser Road	Eliminate gaps	Plainfield	\$1,680,000	MFT, CMAQ, TAP, STP	
17	Construct shared use path on 135 th Street from Meijer store to Eaton Preserve	Provide access to park	Plainfield	\$252,800	MFT, CMAQ, TAP, STP	
28	Extend shared use path across the CN railroad tracks across US 30 on 127 th Street	Increase safety for users crossing the railroad tracks	Plainfield, CN, ICC	\$471,000	MFT, ICC	44
30	Fill-in gaps for shared use path on Van Dyke Road from Lockport Street to north of 143 rd Street	Increase safety for users crossing the railroad tracks	Plainfield	\$305,000	MFT, ICC	12
34	Construct paved shoulders on Plainfield-Naperville Rd from 127 th St to IL 59	Improve bicycle accommodations	Plainfield	\$1,602,000	MFT, CMAQ, TAP, STP	
35	Add bike lanes on Wallin Drive, Van Dyke Road, and Ottawa Street	Connect Lockport Street to the YMCA and Middle School	Plainfield	\$12,500	MFT, CMAQ, TAP, STP	
37	Construct shared use path on Fraser Road/Feeny Drive from Burgundy Drive to Lily Cache Road	Connect to future Park District Bike Path	Plainfield	\$792,400	MFT, CMAQ, TAP, STP	
42	Construct sidewalk on 248 th from 127 th Street to 119 th Street	Eliminate gaps	Plainfield	\$215,700	MFT, TAP	
44	Construct continuous sidewalk on Plainfield-Naperville Road	Improve pedestrian access along corridor	Plainfield	\$1,165,000	MFT, TAP	

Note: Project Number is for location reference only; it does not indicate priority ranking

*Project Funding Legend

MFT = Motor Fuel Tax (State)
 Surface Transportation Program (Federal)
 TAP= Transportation Alternatives Program (Federal)
 ICC = Illinois Commerce Commission (State)
 CMAQ = Congestion, Mitigation, & Air Quality Improvement Program (Federal)



LONG-TERM BICYCLE AND PEDESTRIAN PROJECTS

TABLE 4.3

Number	Action
13	Construct pedestrian bridge across the river at McKenna Drive along the DuPage River Trail (<i>Joliet/Plainfield Township Park District Lead Agencies</i>)
23	Pedestrian signals and crosswalks at County Line Rd & Caton Farm Rd (<i>City of Joliet</i>)
27	Future shared use path intersection improvements at Renwick Rd & US 30
31	Railroad crossing improvements at Plainfield-Naperville Rd—provide paved shoulders across the railroad tracks
32	Future shared use path extension across the railroad tracks at Main St
33	Future shared use path extension across the railroad tracks at Renwick Rd
36	Add a bike lane along Lockport St from DuPage River Bridge to the trail connection at CN Railroad
45	Add sidewalks in all unincorporated subdivisions
46	Add Pedestrian crossing on south side of intersection at IL 59 at US 30

Note: Project Number is for location reference only; it does not indicate priority ranking



SECTION 5 ROADWAY SYSTEM & TRANSIT IMPROVEMENTS

One of the Transportation Plan goals is to create a blueprint to maintain and improve the quality of the existing Village transportation system, reduce auto trips, and enhance and expand the existing transit service in the Village. This Section describes maintenance needs of the Village's roadway system, identifies arterial and collector streets that lack network continuity, intersections with insufficient capacity, outlines ways to improve traffic flow through the Village, and recommends public transit services to reduce auto trips.

The overall Roadway Improvement Plan is illustrated on Exhibit 1 and specific projects are shown in Tables 5, 6, and 7. Significant resident input also went into the development of the plan, both from the web-based community mapping tool, online survey and in-person input at community events and meetings (refer to Appendix A for public comments).

PAVEMENT MAINTENANCE PLAN

According to the US Census Bureau, the Village of Plainfield's population has tripled over the past decade from 13,038 in 2000 to 39,581 in 2010. This population growth was also accompanied by new residential and commercial developments and the rapid expansion of the Village's roadway system. The Village of Plainfield has approximately 203 centerline miles of roadway under its jurisdiction. The Village's Public Works Department creates and administers an annual pavement maintenance program to help keep local Plainfield streets in good working condition.

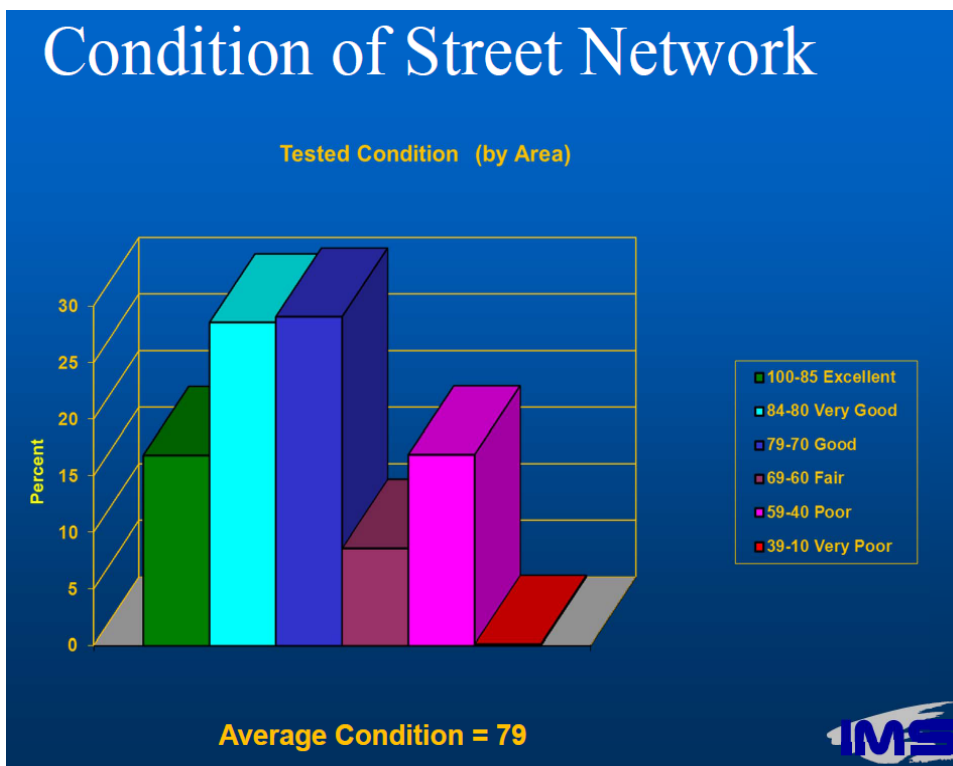

Figure 5.1
Existing
Pavement
Conditions, 2011
Source: 2011
Pavement
Management Report



Village of Plainfield Transportation Plan

A Pavement Management Report was initiated by the Village in 2011. The average pavement condition of Plainfield roadways was rated as “Good” (79). A map illustrating the current condition of Village roadways is included in Appendix D.

A continued investment in the pavement maintenance program is necessary for maintaining convenient and safe circulation and reinforces the Village’s commitment to maintaining residents’ quality of life and providing a supportive business environment. The results of the 2011 Pavement Management Report indicate that if the Village desires to maintain the current condition of its roadways (79), it will require an annual investment of \$4 million. Presently, about \$750,000 per year is allocated to maintain Plainfield’s roadway system.

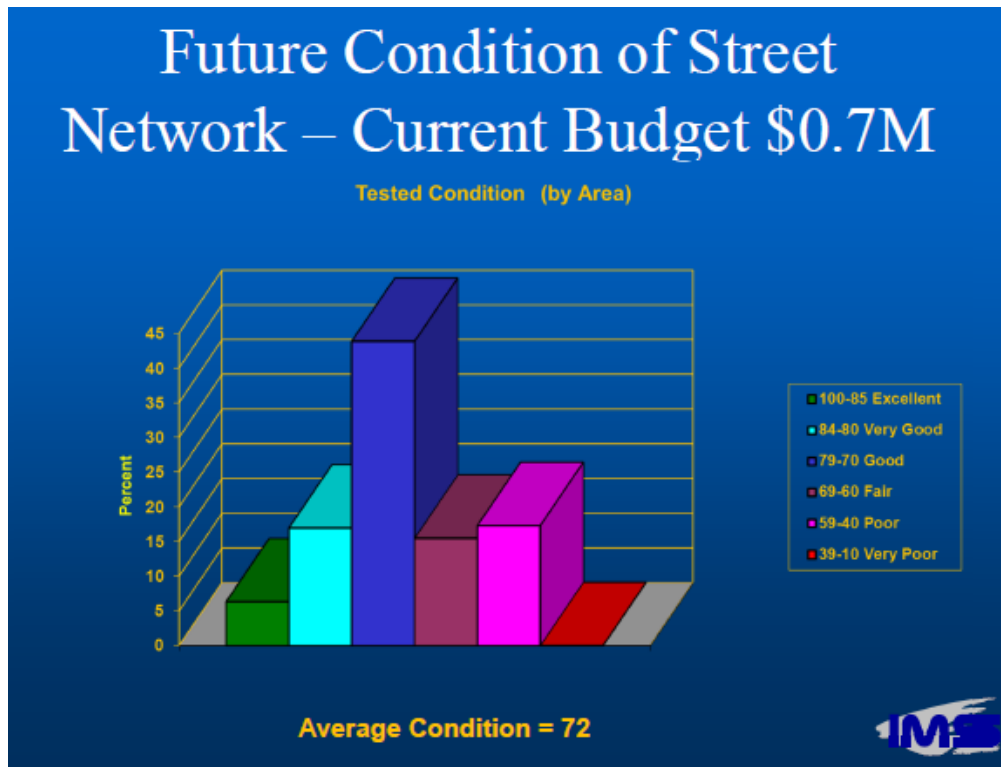

Figure 5.2
Future Pavement Conditions, 2016
Source: 2011 Pavement Management Report

The Village roadway infrastructure is aging and the need for transportation maintenance far outpaces the amount of funding available. Continuing the current investment of about \$750,000 annually will result in an overall Average Condition of 72 after five years (a drop of 7 points) and leave the overall local road network bordering on “Fair” condition. The costs to repair roads that fall into the “Fair/Poor” category are typically much higher and the likelihood of reconstruction vs. resurfacing is much greater.

EXISTING ROADWAY NETWORK NEEDS

The Village of Plainfield and other communities in the Will County region have grown rapidly in recent years and this growth is projected to continue. Traffic volumes have doubled and even tripled along sections of I-55 since the mid-1980's. The Village of Plainfield's downtown core is at the convergence of three State Routes (IL 59, US 30, and IL 126). This area experiences heavy truck volumes and is highly congested. Managing this congestion is a top priority of Village residents. A map of the Existing Transportation System developed as part of the *2013 Comprehensive Plan* and is shown in Appendix C.

Network Capacity

The *2013 Comprehensive Plan* identified the following areas that experience frequent congestion and require capacity improvements:

- IL 59 at US 30: southbound left-turns storage is inadequate.
- US 30 from IL 59 to I-55
- Caton Farm Road (west of IL 59)
- I-55/IL 126 Interchange

During the development of this Transportation Plan, many residents also requested capacity improvements (such as the construction of right turn lanes) at the following intersections with IL 59:

- 135th Street,
- 127th Street, and
- 119th Street.

These recommended improvements are shown in Exhibit 1.

Due to the Village's growth and planned future development, it is important to examine traffic control at each intersection and determine the best method to maximize the capacity of each roadway. Traffic control alternatives (such as two-way stop control, four-way stop control, and traffic signals) and geometric improvements can play an important role in keeping traffic moving efficiently through the Village streets.



Figure 5.3
Capacity Improvements
(such as Right turn lanes) are needed at the major intersections with IL 59

Network Continuity

There are several collector and arterial roadways within the Village that lack network continuity. These discontinuities increase travel times and roadway congestion. IL 59 is the only continuous north-south roadway within the Village of Plainfield. Examples of network discontinuities include:

- Heggs Road does not continue south of 135th Street
- Steiner Road does not continue north of 143rd Street
- Van Dyke Road ends at 119th Street to the north and does not connect to Renwick Road on the south
- The I-55 frontage road is gapped between IL 126 and 143rd Street and between Lockport Road and US 30.
- 143rd Street ends at Steiner Road



Village of Plainfield Transportation Plan

- Offset intersections exist at Indian Boundary Line Road & Renwick Road, Renwick Road and County Line Road, and at Main Street /James Street/Lockport Street.

Access Management

The goal of access management is to provide safe and efficient traffic flow while maintaining access to adjoining properties. This includes regulating the placement of driveways and entrances to minimize the interruption of traffic flow on the main road. Driveways and entrances should be located away from intersections to minimize accidents, reduce traffic interference, and provide adequate storage lengths for vehicles attempting to enter the access points. Curbed medians can be used and median openings can be placed to prevent driveway traffic from interfering with main intersections. Access management decreases accident rates by removing potential conflicts between vehicles accessing driveways and vehicles using the main road.

There is the potential for more industrial and commercial developments within the Village. Because these developments may be constructed on undeveloped land, the Village has developed guidelines regarding the quantity of entrances, their locations, and potential traffic control at intersecting streets. Village guidelines for access spacing include the following:

- Minimum 1/2-mile spacing between full access points.
- Minimum 1/4-mile spacing between restricted access points (for example, right-in/right-out) spacing.
- No access permitted within 600 feet of a signalized intersection.

Specific access management strategies for each corridor should be examined further in a future update of the Transportation Plan

RECOMMENDED IMPROVEMENTS TO THE PLAINFIELD ROADWAY NETWORK

The Village Village-wide roadway priorities include improving access to I-55, development of the WIKADUKE Trail, the extension of 143rd Street east of Illinois Route 59, and the re-route of Illinois Route 126. The overall Roadway Improvement Plan is illustrated on Exhibit 1 and specific projects are shown in Tables 5, 6, and 7. Some of the overall recommendations to improve the quality of the existing Village transportation system are discussed below.

INTERSTATE 55

US 30 Interchange—US 30 at I-55 is a full access Interchange. It is a grade-separated diamond configuration with single lane exit and entrance ramps. The US 30/I-55 Interchange serves as an access point for traffic from the southern parts of Plainfield, Romeoville, Lockport, Crest Hill, and the northern part of Joliet.

IL 126 Interchange—IL 126 is an east-west route that terminates at I-55. This partial access interchange was originally constructed by converting each lane of IL 126 into ramps for the interstate. Presently, service at the IL 126 interchange is limited to northbound entrance movements to I-55 and southbound exit movements from I-55 to IL 126.

Potential I-55 Improvements at Airport Road and IL 126/Essington Road

The Villages of Romeoville, Plainfield, and Bolingbrook, along with IDOT and the Federal Highway Administration (FHWA), are currently involved in the Phase I Study and Planning process for access improvements to Interstate 55. The I-55 study area is located between the Weber Road and



US Route 30 Interchanges. The purpose of this project is to provide improved access to Interstate 55 and

- Improve regional connectivity
- Accommodate forecasted travel demands
- Reduce delay due to adverse travel demand on the local roadway network.

An interchange at Lockport Street/Airport Road and I-55 is proposed as part of this study. The Village of Plainfield identified a connector road from 143rd Street to Lockport Street in the alternatives being studied. The 143rd Street connection has been named the Lockport Street bypass by the Village of Plainfield. This bypass is intended to route truck traffic at the future Lockport/Airport Rd Interchange up to 143rd Street. This bypass will enable motorists and truck traffic to travel to the major commercial and industrial areas within the Village without having to travel through the heavily congested downtown core.

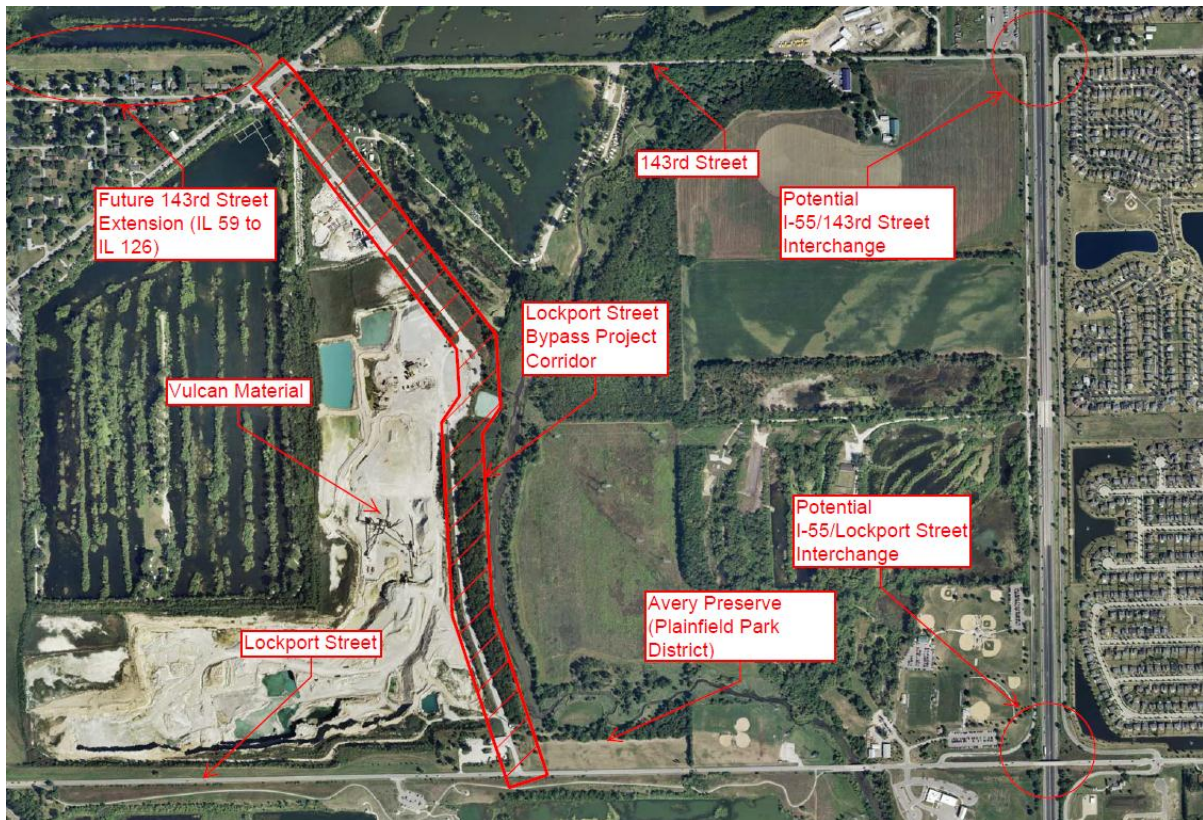

Figure 5.3 Lockport Street Bypass Location Map

The Lockport Street Bypass will enable motorists to access to the major commercial and industrial areas in Plainfield without having to travel through the downtown core.

The proposed Phase I of the I-55 Interchange Study is fully funded with Federal and local funding. However, Phases II and III are not currently included in the Department’s Proposed Multi-Modal Transportation Improvement Program but will be considered for inclusion in future programs.



Village of Plainfield Transportation Plan

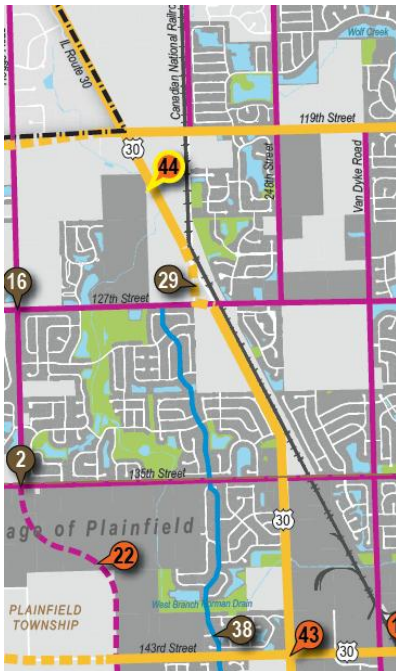

US 30

US 30 is an arterial roadway that carries regional traffic through the Village of Plainfield. It also provides access to Interstate 55. US 30's two-lane rural roadway is experiencing traffic volumes near the threshold for a four-lane roadway. Growth in the western and northern areas of the Village will result in traffic volumes exceeding the available capacity on US 30.

A Phase I Engineering Study is recommended on US 30 from 119th Street to 143rd Street to address capacity concerns. IDOT is currently in Phase II engineering for the improvement of US 30 from IL 59 to I-55. Construction is anticipated in 2014.

Figure 5.4 US Route 30 Phase 1 Engineering Study

Improvements are needed on US 30 between 119th Street and 143rd Street to upgrade the roadway, increase capacity, and serve projected traffic demand (labeled as #43 in this figure).

WIKADUKE TRAIL (RIDGE ROAD)

The WIKADUKE Trail is part of the Strategic Regional Arterial (SRA) system as designated by the Illinois Department of Transportation (IDOT) and the Chicago Metropolitan Agency for Planning (CMAP). The 2013 *Comprehensive Plan* defines the underlying concept behind this project to be the provision of a continuous major north-south arterial to serve growing travel demand in northwest Will County and Northeast Kendall County and link these areas with western DuPage County and northeastern Grundy County. The WIKADUKE Trail will be a major north-south arterial roadway on the west side of Plainfield in Kendall County. It will connect Eola Road in Aurora to Interstate 80 and is designed to ease congestion along the Village's north-south roadways.

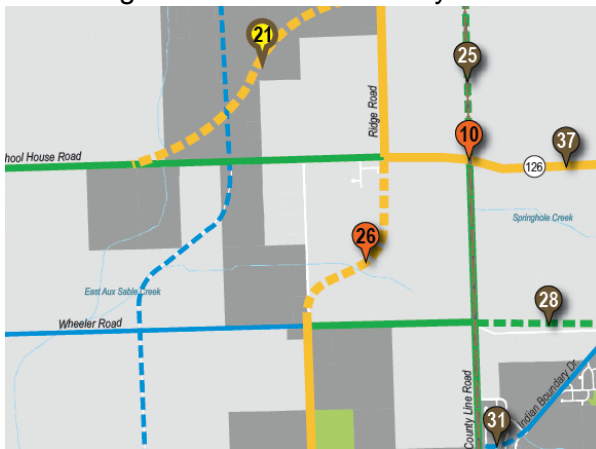

Figure 5.5 Ridge Road Extension

This key segment is labeled as #26 on Exhibit 1 and will be part of the future WIKADUKE Trail.

IDOT completed an extensive study of the WIKADUKE Trail to determine the ultimate improvements needed to accommodate future traffic at an acceptable level of service. The proposed alignment within the Village of Plainfield will be on Ridge Road.

Kendall County will be constructing a new roadway between Wheeler Road and IL 126 in 2013.

DRAUDEN/STEINER/HEGGS ROAD

The Drauden/ Steiner/ Heggs corridor is planned to be a new major collector facility that will serve growth in western Plainfield and commuter travel between Aurora, Naperville, Shorewood, and Joliet. These improvements will expand the existing collector street network and to provide a continuous, north-south alternative to Illinois Route 59.

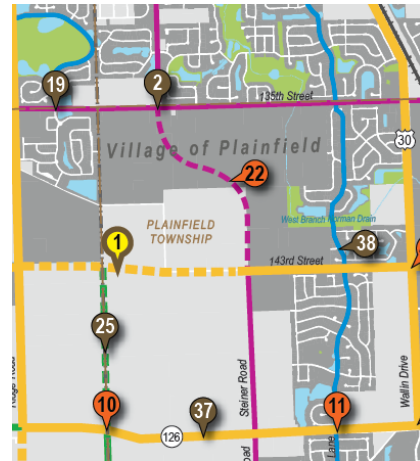

Figure 5.6 Drauden/Steiner Heggs Connection
The connection between Steiner Road and Heggs Road is labeled #22 on Exhibit 1.

119TH STREET

119th Street is part of the Strategic Regional Arterial (SRA) system as designated by the Illinois Department of Transportation (IDOT) and the Chicago Metropolitan Agency for Planning (CMAP). 119th Street will be a four lane Roadway connecting the WIKADUKE Trail (Ridge Road) with IL 59. These improvements are driven by the continued growth that is expected in the Plainfield, Naperville, Oswego, Bolingbrook, and Aurora.

The future 119th Street SRA includes a new connector road between Collins Road in Oswego and 119th Street in Plainfield. This alignment is presented in Exhibit 1 and is shown in Figure 5.7 below.

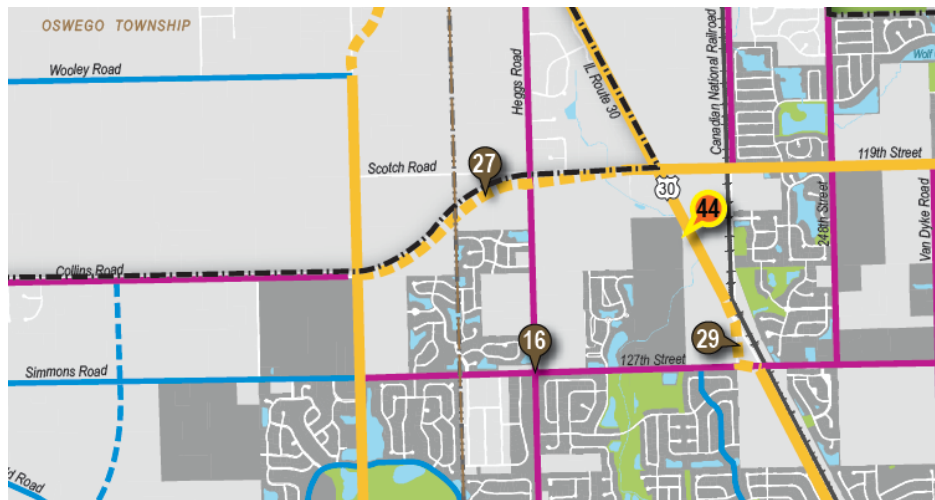

Figure 5.7 119th Street Extension
The geometry of the 119th Street extension will determine the Village limits between Plainfield and Oswego.

RENWICK ROAD

Plainfield Township recently completed the construction of a new, two-lane Renwick Road Bridge over the DuPage River, including a major roadway realignment near the river. The project will significantly improve the east-west traffic flow between southwestern Plainfield and the major traffic corridors east of the DuPage River. Reconstruction and/or resurfacing of Renwick Road between River Road and US 30 is required to accommodate the expected increase in traffic.



Figure 5.8 Renwick Road Improvements

The recently constructed bridge over the DuPage River will result in increased traffic volumes on Renwick Road.

IL ROUTE 126

The current location of Illinois Route 126 serves two major components of travel – regional traffic, destined for Interstate 55, other connecting roadways, and local traffic destined for downtown Plainfield. To accommodate the increased traffic into the Village and to expedite regional traffic flow, the *Comprehensive Plan* and 2006 Corridor Study called for relocating IL Route 126 to 143rd Street.

The future IL 126 alignment includes new connector road between School House Road and 143rd Street and between IL 59 and IL 126. This alignment is presented in Exhibit 1 and is shown in the figure below.

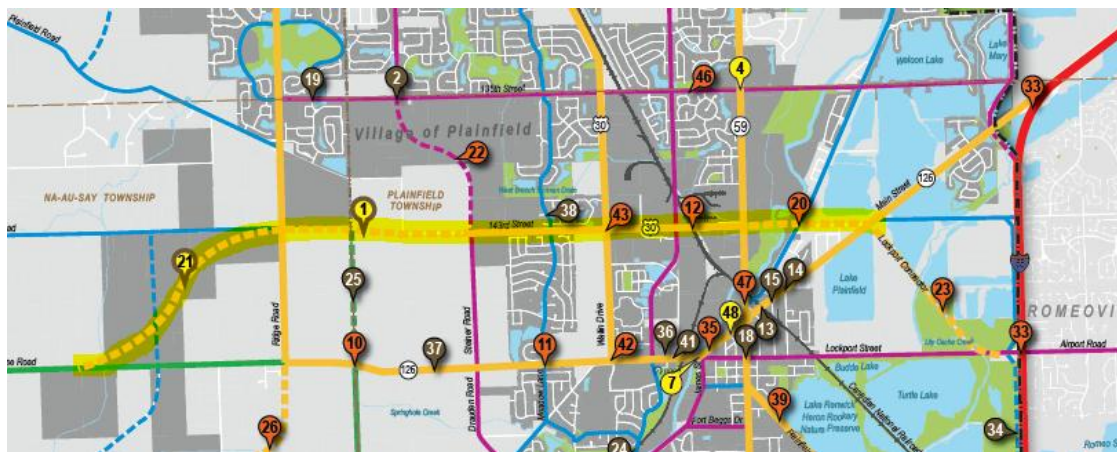

Figure 5.9 IL 126 Realignment

The proposed alignment for IL 126 is highlighted in yellow.



POTENTIAL PUBLIC TRANSIT SERVICES

Public transportation service in the Plainfield area is very limited. The on-line surveys and public meetings revealed a strong interest in better access to public transportation for seniors and lower income residents, others with special needs, and for residents to reduce auto trips. Some of the recommended services identified by residents via the on-line comment form or at public meetings are summarized in Table 5.1 below. Specific comments from residents are shown on Page 15 in Appendix A.

PUBLIC TRANSIT NEEDS IDENTIFIED BY RESIDENTS

TABLE 5.1

Number	Action
47	Provide Pace Bus service between downtown Plainfield and Joliet/Metra Station
48	Provide Pace Bus service along IL Route 59 thru Plainfield and to the IL Route 59 Metra Station
49	Increase the frequency of Pace service along I-55 to downtown Chicago— <i>completed May 2013</i>
50	Provide a permanent parking lot for Pace Park & Ride services

*Note: Project Number is for location reference only; it does not indicate priority ranking
Each of these Actions should be the subject of further study by Plainfield and the transit agencies.*

IMPLEMENTATION OF TRANSIT IMPROVEMENTS

In response to the interests identified by Plainfield residents, the key transit recommendations for this Transportation Plan are the following:

- Work with the RTA, CMAP, Pace, and Metra to conduct a market analysis of the Plainfield area to determine the best way to meet resident's needs. Additional studies are needed to assess the market, understand current and potential users' travel needs and expectations, and evaluate the costs and potential benefits that may be result from transit service improvements within the community.
- Support the expansion of public transit services. Continue working with Pace and Metra about providing/expanding service improvements within the Village.

In addition, the bicycle and pedestrian systems should be expanded to provide connections to neighborhood amenities and provide support for future transit. If someone can easily and conveniently walk or bike to a transit stop, they are more likely to choose transit.



Village of Plainfield Transportation Plan

IMPLEMENTATION OF ROADWAY IMPROVEMENTS

The overall Roadway Improvement Plan is illustrated on Exhibit 1 and specific projects are shown in Tables 5, 6, and 7. Significant resident input also went into the development of the Plan, both from the web-based community mapping tool, online survey and in-person input at community events and meetings. Projects were prioritized based on public, Village Board and staff input, project readiness, potential for receiving matching funds, cost, and feasibility. High priority projects are those that can be built within a 5-year time frame. Moderate priority projects are those that can be built within the next 5 to 10 years. Long term considerations are those that are anticipated to be constructed beyond the 10 year period, require significant funding, and usually involve right of way acquisition. Most Moderate and Long Term projects do not have guaranteed funding sources.

A simple and cost-effective way to integrate non-motorized users into the design and operation of the transportation system is to include bicycle and pedestrian accommodation as an incidental part of larger ongoing projects. Examples include:

- Providing paved shoulders on new and reconstructed roads.
- Restriping roads (either as a stand-alone project or after a resurfacing or reconstruction project) to create a wider outside lane, Sharrows, or striped bike lanes.
- Building sidewalks and trails, and marking crosswalks or on-street bike lanes as a part of a roadway improvement.

Many of the bicycle and pedestrian projects in this Plan may be incorporated into a larger capital improvement by the Village. These projects are cross-referenced in each Table.

Projects that receive federal funding progress through 3 phases:

- **Phase I:** Transportation needs and deficiencies will be identified, alternatives will be developed and evaluated, and a preferred plan will be selected and potential Right-of-Way identified.
- **Phase II:** Detailed Construction Plans will be developed and land will be acquired.
- **Phase III:** Construction begins.

A cost analysis was performed for the Short-Term and Moderate considerations with a base cost in 2013 dollars. Segments were analyzed between major intersections and a cost analysis was provided for each segment. Major cost items include right of way acquisition, construction of the hot-mix asphalt pavement, sidewalk and bicycle path construction, earthwork, storm sewers, removal and disposal of unsuitable soils and materials (assuming poor soil quality), and roadway lighting. Intersection improvements included the following: traffic signal installation, transitional intersection lighting, reconstruction of the pavement of the intersecting street to provide auxiliary lanes, and right of way acquisition. Items estimated as a percentage of total construction cost included maintenance of traffic, contractor mobilization, erosion control, relocation of utilities, contingency, and engineering required to design and construct the improvements.





HIGH PRIORITY ROADWAY PROJECTS (0 TO 5 YRS)

TABLE 5.2

Project Number	Action	Purpose	Participants	Preliminary Estimate of Cost	Possible Funding Sources	Corresponding Bike/Ped Project Number
6	Plainfield-Naperville Road & 127 th Street Intersection Improvements	To increase roadway capacity and to improve intersection operations	Plainfield, Bolingbrook, Will County	\$3,140,000	MFT, STP, HBP	3, 5
10	Reconstruct IL 126 & County Line Road Intersection, Add turn lanes and traffic signals	To increase roadway capacity and to improve intersection operations	Kendall County, Plainfield	\$1,150,000	Kendall County, MFT, STP, HSIP	
11	Traffic Signal Study at IL 126 & Meadow Lane (IDOT is Lead Agency)	To improve intersection operations	Plainfield, IDOT	By IDOT		19
12	Grade Separation—Phase 1 Study at 143 rd Street & CN Railroad Crossing	To reduce congestion due to increased rail traffic	Plainfield, CN, ICC, FRA, IDOT	\$2,400,000	ICC, MFT, State, STP	30
20	Phase 2 Engineering Study, 143 rd Street Extension from IL 59 to IL 126	To improve east-west regional access through the region and to serve projected traffic demand.	Plainfield	\$900,000	MFT, STP	
22	Construct new roadway between 143 rd Street and 135 th Street (Drauden/Steiner/Heggs Connection)	To improve north-south regional access through the Village and to serve projected traffic demand.	Plainfield	\$6,250,000	MFT, STP	
23	Lockport Street- Bypass Feasibility Study	To improve regional access through the Village and to serve projected traffic demand created by I-55 improvements	Plainfield	\$200,000	MFT	
26	WIKDADUKE Trail (Ridge Road)-Construct new roadway between Renwick Road and IL 126	To improve north-south regional access through the Village and to serve projected traffic demand.	Kendall County	<i>By County, \$8,360,000</i>		
32	Reconstruct Renwick Road from River Road to IL 59	To upgrade roadway and serve projected traffic demand	Plainfield, Plainfield Township	\$5,230,000	MFT, STP, Plainfield Township	10, 26
33	Conduct I-55 Interchange Study (I-55 at IL 126 and I-55 at Lockport Street/Airport Road)	To improve regional access to adjoining communities and serve projected traffic demand	IDOT, FHWA, Bolingbrook, Romeoville, Plainfield	\$400,000	MFT, State, STP	
35	Resurface IL 126 from Wallin Drive to IL 59	To extend pavement service life	IDOT	<i>By State, \$600,000</i>	State	20, 21, 53
39	Widen and Reconstruct US 30 from IL 59 to I-55	To upgrade roadway, increase capacity, and serve projected traffic demand	IDOT	<i>By State, \$32,469,000</i>	State	27, 46
42	IL 126 & Wallin Drive Intersection Improvements (traffic signals and pedestrian crossings)	To improve traffic flow , pedestrian access, and intersection operations	Plainfield	\$450,000	MFT	8, 20
43	Reconstruct intersection & install permanent traffic signals at 143 rd Street & US 30	To improve traffic flow and intersection operations	Plainfield, IDOT	\$2,800,000	MFT, State, STP	7
44	Phase 1 Engineering Study to reconstruct US 30 from 119 th Street to 143 rd Street	To upgrade roadway, increase capacity, and serve projected traffic demand	Plainfield, IDOT	\$1,050,000	MFT, STP	28
45	Reconstruct 127 th Street from IL 59 to DuPage River	To upgrade roadway, increase capacity, and serve projected traffic demand	Plainfield, Wheatland Township	\$5,630,000	MFT, STP	5
46	Widen and Resurface 135 th Street from Van Dyke Road to IL 59	To upgrade roadway and reduce congestion	Plainfield	\$4,530,000	MFT, STP	52
47	Reconstruct Renwick Road from IL 59 to US 30 to provide a 5 lane roadway section	To upgrade roadway and serve projected traffic demand	Plainfield	\$3,800,000	MFT, STP, Plainfield Township	27, 41

Note: Project Number is for location reference only; it does not indicate priority ranking

*See next page for Funding Legend



MODERATE PRIORITY ROADWAY PROJECTS (5 TO 10 YRS)

TABLE 5.3

Project Number	Action	Purpose	Participants	Preliminary Estimate of Cost	Possible Funding Sources*	Corresponding Bike/Ped Project Number
1 & 21	Complete Phase 1 Engineering Study to construct 143 rd Street Extension—County Line Road to Steiner Road, S-Curve from Lockport Street/Schoolhouse Road to 143 rd Street	To improve east-west regional access through the region and to serve projected traffic demand.	Plainfield	\$1,420,000	MFT	
3	IL 59 & 119 th Street Intersection Improvements (Widen pavement to add turn lanes & upgrade traffic signals)	To improve traffic flow	Plainfield, IDOT	\$2,480,000	MFT, STP, TAP	25
4	IL 59 & 135 th Street Intersection Improvements (Widen pavement to add turn lanes & upgrade traffic signals)	To improve traffic flow	Plainfield, IDOT	\$2,480,000	MFT, STP, TAP	52
5	IL 59 & 127 th Street Intersection Improvements (Widen pavement to add turn lanes & upgrade traffic signals)	To improve traffic flow	Plainfield, IDOT	\$2,090,000	MFT, STP, TAP	22
7	Main Street/James Street Intersection Realignment	To improve safety	Plainfield, IDOT	\$3,140,000	MFT, STP, HSIP	
12	Complete Phase 2 Engineering and Construct grade-separated railroad crossing at 143 rd Street & CN Railroad	To reduce congestion due to increased rail traffic	Plainfield, CN, ICC, FRA, IDOT	\$30,000,000	ICC, CN, MFT, State, Grade Crossing Protection Program, STP	
20	Construct 143 rd Street Extension from IL 59 to IL 126	To improve east-west regional access through the region and to serve projected traffic demand.	Plainfield	\$19,400,000	MFT, STP	
44	Phase 2 Engineering study to reconstruct US 30 from 119 th Street to 143 rd Street	To upgrade roadway, increase capacity, and serve projected traffic demand	Plainfield, IDOT	\$1,050,000	MFT, STP	28
48	Widen asphalt shoulders on IL 126 from Lockport Street to IL 59	To improve safety for bicyclists	Plainfield, IDOT	\$230,000	State, MFT, STP	53

Note: Project Number is for location reference only; it does not indicate priority ranking

*Project Funding Legend

MFT = Motor Fuel Tax (State)
 Surface Transportation Program (Federal)
 TAP= Transportation Alternatives Program (Federal)
 ICC = Illinois Commerce Commission (State)
 CMAQ = Congestion, Mitigation, & Air Quality Improvement Program (Federal)
 HSIP = Highway Safety Improvement Program (Federal)
 HBP = Highway Bridge Program (Federal)
 CN = Canadian National (private)



LONG-TERM ROADWAY PROJECTS
TABLE 5.4

Number	Action
1 & 21	Construct 143 rd Street Extension—County Line Road to Steiner Road, S-Curve from Lockport Street/Schoolhouse Road to 143 rd Street
2	Install traffic signals at 135 th Street & Heggs Road
8	111 th Street at US 30--Channelization and traffic signals (IDOT is Lead Agency)
9	IL 126 at Schlapp Road—Channelization and traffic signals (IDOT is Lead Agency)
13	Construct Grade Separated Railroad Crossing at Main Street & CN Railroad
14	Eastern Avenue & IL 126 Intersection Improvements
15	Center Street & IL 126 Intersection Improvements
16	Heggs Road & 127 th Street Traffic Signal Installation
18	Add Streetscaping/Gateway Signage on IL 59 near Lockport Street
19	Grande Park Blvd Traffic Signal Installation at 135 th Street
24	Van Dyke Road Extension—Lockport Street (IL 126) to Renwick Road
25	County Line Road Extension—IL 126 to 143 rd Street (Development project)
27	119 th Street Realignment—Ridge Road to US 30
28	Renwick Road Realignment—County Line Road to Indian Boundary Road
29	US 30 Realignment at 127 th Street Intersection
30	Rolf Road realignment at Lily Cache Road
31	Indian Boundary Road realignment at County Line Road (Development project)
34	Construct I-55 Frontage Roads—from US 30 to IL 126 (IDOT is lead agency)
36	Provide on-street parking on Lockport Street at Town Square (across from Village Hall)
37	Conduct Speed Limit Study on IL 126 from County Line Rd to Wallin Drive
38	Install traffic calming measures on Meadow Lane
40	Widen IL 59 to three lanes in both directions from 95 th Street to Caton Farm Road (IDOT Project)
41	Continue the downtown streetscaping improvements west of DuPage River to Van Dyke Road

Note: Project Number is for location reference only; it does not indicate priority ranking

Section 6 Funding Mechanisms

It is essential that the Village have enough revenue to implement the projects identified in the Plan and maintain the Village's transportation system. Funding for the Transportation Plan improvements will come from several public sources including federal, state, county, and township programs, as well as from private sector development. Some of the funding streams available that the Village can use towards transportation projects and are described in the following sections:

- General Revenue,
- Developer-funded improvements,
- Motor Fuel Tax Fund, and
- Federal funding

GENERAL REVENUE

The Village's general fund revenue for fiscal year 2013-14 is approximately \$20.9 million. General revenue is derived from a variety of sources, which are illustrated in the figure below:

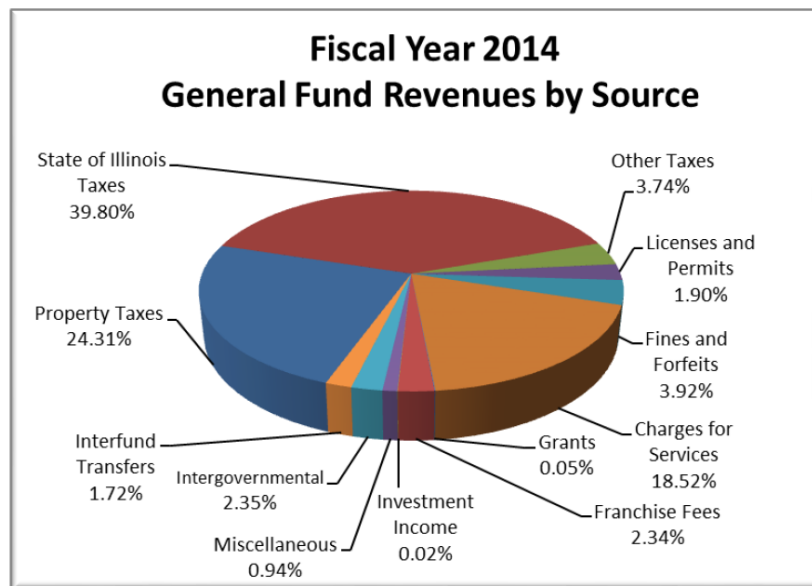

Figure 6.1
Village Of Plainfield General Fund Revenues, FY2013-14

The Village of Plainfield's local gas tax is 4 cents per gallon. The Village also receives a 1% municipal sales tax imposed on retail sales made within the Village of Plainfield. The revenue generated by these taxes is used to fund the Public Works Department, Plainfield Police Department, Administration, Building Department, Planning Department, and provide other vital services to Village residents. The Village also uses these revenues to fund transportation improvements. The Village's 2013-14 capital budget includes \$3.1 million for roadway, bridge, bike path, and signal engineering and improvements.



General Obligation Bond (GOB) Issue

Issuing general obligation bonds is one way to finance an entire project or to finance the Local Match of a project receiving federal funding. The Lockport streetscape project is one such example of financing transportation improvements through general obligation bonds. \$6.5 Million in bonds were secured to fund the downtown Plainfield improvements and the Village is currently using sales tax revenues to repay bond holders.

Vehicle Stickers

In years past, the Village of Plainfield issued vehicle stickers for all motor vehicles registered to an address within the Village limits. The fees provided approximately \$250,000/year in revenue for the Village, which was used for maintaining existing roadways. The Village may consider reinstating motor vehicle registration/vehicle stickers to provide additional funds for roadway maintenance, such as the annual resurfacing program.

DEVELOPER-FUNDED IMPROVEMENTS

Between 2000 and 2010, the population tripled within the Village of Plainfield. This population growth was also accompanied by new residential and commercial developments and the rapid expansion of the Village's roadway system. The Renwick Road and Drauden Road improvements were built in conjunction with the Springbank and Creekside subdivisions and are examples of major roadway projects that were designed, built, and funded by developers.

Traffic Impact Fees

New developments within the Village generate vehicular traffic and put a strain on the existing roadway system. Through the imposition of traffic impact fees, new developments have historically provided an additional funding source for roadway improvements within the Village of Plainfield. Traffic impact fee revenues were as high as \$1.3 Million in 2006/07. These fees are currently suspended, but the Village may consider reinstating the traffic impact fee when the housing market begins to expand.

The dramatic downturn in the economy also brought the housing market to a halt, which stalled the growth of the Village in recent years. An improving economy will once again stimulate growth within the Village and put a strain on the existing roadway system. However, the developer-funded capital improvements cannot be depended upon when the housing market begins to expand again in the future. The Village of Plainfield must find ways to finance the improvements, such as increasing capacity and constructing intersection improvements, with less financial assistance from developers.

MOTOR FUEL TAX (MFT)

The Illinois Motor Fuel Tax (MFT) Fund is derived from a tax on operating motor vehicles on public highways and is distributed in proportion to population. MFT funds can be used for capital improvements and maintenance. The Village of Plainfield's MFT allotment is approximately \$1.1 Million annually, which is used on the annual resurfacing program, snow removal, and de-icingsalt purchases.



Village of Plainfield Transportation Plan

The MFT fund provides revenue that is dedicated to roadway-related improvements, but the \$1.1 Million allotment is about one-fourth of the \$4 million annually needed to maintain the current condition of the Village's 203 centerline miles of roadways.

Motor Fuel Tax (MFT) Bond Issue

The Village is allowed to bond up to one-half of its annual MFT allotment for the purpose of implementing transportation construction projects. The Village receives approximately \$1.1 Million per year in Motor Fuel Tax disbursements from the State of Illinois. As an example, if the Village were to bond one-half of its annual MFT allotment for 10 years, approximately \$5,500,000 could be generated towards the Local Match of a federally-funded project. The downside to this approach is that these funds would not be available for other important transportation improvements in the Village for a ten-year timeframe.

FEDERAL FUNDING

On July 6, 2012, President Obama signed into law P.L. 112-141, the Moving Ahead for Progress in the 21st Century Act (MAP-21). MAP-21 is the first long-term highway authorization enacted since 2005. Several new federal programs were established and many others were consolidated. The maximum federal participation for a project is generally 80%, which requires a minimum 20% local match. The resources for the local match may include general revenue, motor fuel tax revenue, impact fees, State funds, developers, or businesses. Presented below are federal programs available for roadway and walking/bicycling projects in the Village of Plainfield.

Roadway Projects

Federal funding for roadway improvements includes programs such as Surface Transportation Program (STP), Congestion Mitigation and Air Quality (CMAQ), and the Highway Safety Improvement Program (HSIP). Projects must meet federal eligibility rules and most must be on roadways that are on the Federal-Aid Highway System. The 5-Year Classification Maps are included in the Appendix and illustrate which routes are on the Federal-Aid Highway System. At a minimum, roads need to be classified as a Collector to be eligible for Federal Aid funds. The following Village roadways are Federal Aid Routes and are therefore eligible for Federal-Aid funding; Renwick Road, Fraser Road, Fort Beggs Drive, 143rd Street, 135th Street, 119th Street, River Road/James Street, Van Dyke Road and Drauden/Steiner Road. It is recommended that Village streets serving a collector function, such as 127th Street, be added to the Federal Aid Route system. Then, the Village may receive Federal funding assistance for projects on those roadways.

Bicycle and Pedestrian Projects

Federal funding for bicycle and pedestrian infrastructure improvements is available through the Transportation Alternatives Program (TAP). This program is administered by IDOT and projects must meet federal eligibility rules. The TAP replaces funding from pre-MAP-21 programs, such as the Illinois Transportation Enhancements Program (ITEP), Recreational Trails Program (RTP), Safe Routes to School (SRTS), and several other discretionary programs, and wraps them into a single funding source.



Village of Plainfield Transportation Plan

The Chicago Metropolitan Agency for Planning (CMAP) also maintains a list of potential funding sources for walking/bicycling projects and programs in Northeastern Illinois at <http://www.cmap.illinois.gov/bike-ped/funding-sources>.

Surface Transportation Program (STP)

The Federal Surface Transportation Program provides funding to municipalities for projects on the Federal-Aid Highway System. Eligible projects include roadway reconstruction, road rehabilitation, pavement widening/add lanes, intersection improvements, traffic signals, Right of Way acquisition, street lighting, sidewalks and storm sewer improvements. The Will County Governmental League (WCGL) receives approximately \$5 million a year in STP funds and is responsible for programming the funds for transportation improvements within Will County. The WCGL STP Funding Methodology is as follows:

- No Federal participation in Phase I Engineering and Right-of-Way Acquisition.
- 80% maximum Federal participation in Phase II Engineering.
- Construction and Construction (Phase III) Engineering is funded at a maximum Federal Participation of 80%.
- The WCGL limits their federal participation on any one project to \$2,500,000.

Approximately every 3 years, there is a call for eligible projects. Each project is ranked and then selected to be included in the Surface Transportation Program.

Congestion Mitigation and Air Quality Improvement Program (CMAQ)

The CMAQ program funds transportation projects to help the Chicagoland region meet the requirements of the Clean Air Act Amendments of 1990. The CMAQ program encourages the construction of projects that will reduce congestion and/or provide an air quality benefit through transportation improvements. The federal participation amount for CMAQ projects is 80% with a 20% local match. Eligible projects include the following:

- Traffic flow improvement projects (bottleneck elimination, intersection improvements such as adding turn lanes or traffic signals). Potentially eligible for funding are the following intersections; IL 59 at 119th Street, IL 59 at 127th Street, and IL 59 at 135th Street.
- Traffic signal interconnects to provide better progression along major corridors.
- Transit projects.
- Bicycle and pedestrian facility projects.
- Bicycle parking/bicycle encouragement projects.
- Commuter parking projects

CMAQ funds are administered by the Chicago Metropolitan Agency for Planning (CMAP). CMAP typically has a call for project applications in December of each year.

Highway Safety Improvement Program (HSIP)

The HSIP program is a federal-aid funding program with the goal of achieving a significant reduction in traffic fatalities and serious injuries on all public roads. Highway safety improvement projects correct or improve a hazardous road location or feature, or address a highway safety problem. Examples include guardrail, intersection



Village of Plainfield Transportation Plan

channelization, signing and pavement markings or other similar elements. To achieve the maximum benefit, the program focuses on cost effective use of the funds allocated for safety improvements. Priority is typically given to projects having a higher total number of fatalities and serious injuries affected. Approximately \$9 million in funding for the local highway system in the State of Illinois was available in 2012.

All phases of safety improvement projects are eligible for reimbursement, including preliminary engineering, land acquisition, construction, and construction engineering. The federal funding level is a maximum of 90% of the total improvement cost with the local agency responsible for the 10% matching funds. Applications for the HSIP are received annually by the Illinois Department of Transportation at District 1.

Transportation Alternatives Program (TAP)

The Transportation Alternatives Program (TAP) is a federally-funded competitive program that promotes alternative means of transportation. TAP provides funding for community based projects that expand travel choices and enhance the transportation experience by improving the cultural, historic, aesthetic and environmental aspects of transportation infrastructure. The Village may receive up to 80 percent reimbursement for eligible project costs. The remaining 20 percent is the responsibility of the Village. Eligible projects include the following:

- Construction, planning, and design of infrastructure-related projects and systems that will provide safe routes for non-drivers, including children, older adults, and individuals with disabilities to access daily needs.
- Conversion and use of abandoned railroad corridors for trails for pedestrians, bicyclists, or other nonmotorized transportation users.
- Construction of turnouts, overlooks, and viewing areas.
- Community improvement activities, including—
 - inventory, control, or removal of outdoor advertising;
 - historic preservation and rehabilitation of historic transportation facilities;
 - vegetation management practices in transportation rights-of-way to improve roadway safety, prevent against invasive species, and provide erosion control; and
 - archaeological activities relating to impacts from implementation of a transportation project.
- Any environmental mitigation activity, including pollution prevention and pollution abatement activities and mitigation to—
 - address stormwater management, control, and water pollution prevention or abatement related to highway construction or due to highway runoff; or
 - reduce vehicle-caused wildlife mortality or to restore and maintain connectivity among terrestrial or aquatic habitats.

Federal-aid programs can contribute a significant portion of the funds needed for transportation improvement projects. However, the administrative burden of a federal-aid project is substantial. In addition, the project scope and scale of a project may expand because of federal procedures and standards. Projects must be refined through the National Environmental Policy Act (NEPA) process, which can add years to the project



schedule. The NEPA process evaluates social and economic impacts, impacts to agricultural land, cultural impacts, and effects on air quality, noise, natural resources, water quality, flood plains, wetlands, special waste, and other issues. Federal-aid procedures also require that a problem has to be looked at systematically over a twenty-year planning horizon. This may involve changes that significantly increase the cost of the project (and the amount of matching funds required of the Village).

Section 7 Recommendations

The Village's transportation system influences patterns of growth and economic activity by providing access to land and providing for the mobility of people and goods. To prepare the Village of Plainfield for future growth and meet the challenges of traffic congestion, more work is needed.

This Plan describes the improvements for roadway, bicycle, pedestrian and transit improvements, provides associated cost estimates, and discusses potential funding mechanisms. The key recommendations in the Plan include the following:

- Support the expansion of public transit services. Continue working with Pace and Metra about providing/expanding service improvements within the Village.
- Work with the RTA, CMAP, Pace, and Metra to conduct a market analysis of the Plainfield area to determine the best way to meet resident's needs. Additional studies are needed to assess the market, understand current and potential users' travel needs and expectations, and evaluate the costs and potential benefits that may be result from transit service improvements within the community.
- Add collector roadways to the Federal Aid Route System to make them eligible for Federal Aid funds.
- Use the prioritized list of projects and cost estimates to apply for federal or State funds when they become available.
- Expand the bicycle and pedestrian systems to provide connection to neighborhood amenities and provide support for future transit. By providing alternate means for people to travel within the community, roadway congestion can be reduced.
- Work with IDOT to eliminate bicycle/pedestrian gaps on State roadways.
- Consider a General Obligation or Alternative Revenue (sales tax) Bond issue.
- Continue seeking meaningful developer contributions/improvements.
- Consider an MFT Bond issue.
- Reinstate Village vehicle stickers.
- Reinstate development traffic impact fee.

This Transportation Plan will serve as a guide and provide a framework for capital improvements within the Village. This Plan incorporates the public perspective on potential improvements and will also be an invaluable tool to aid in applying for funding. Several revenue sources that can help fund the transportation improvements within the Village are presented in this report. However, the range of funding options available versus the significant costs of the improvements presents numerous challenges.



Village of Plainfield Transportation Plan

The total cost of the High Priority bicycle, pedestrian and roadway projects presented in this Plan is \$52.2 million. Constructing these improvements within the next 10 to 20 years would require a significant annual investment, in addition to yearly roadway maintenance costs. Approximately \$4 million per year is needed to maintain the current condition of the Village's existing roadway system. Regular and scheduled maintenance of the Village's roadway facilities helps ensure the continuation of high quality services.

The Village should consider allocating additional financial resources to fund the roadway, bicycle, and pedestrian improvements discussed in this Plan. Based on the funding made available, a new, 5-Year Capital Plan can be developed to implement the Village's vision for the future.



References

FEDERAL OR STATE DOCUMENTS

GO TO 2040 Regional Comprehensive Plan, CMAP

*Bureau of Design & Environment Manual, Chapter 17-Bicycle and Pedestrian
Accommodations, IDOT, 2013*

*Guide for the Planning, Design, and Operation of Bicycle Facilities, Fourth Edition,
AASHTO, 2012*

*The Transportation Planning Process: Key Issues Publication Number FHWA-HEP-07-039,
FHWA & FTA, September 2007*

Manual on Uniform Traffic Control Devices (MUTCD) 6th Edition, AASHTO, 2011

Illinois Long Range State Transportation Plan-Freight Mobility Plan, November 2012

WEBSITES

Federal Highway Administration, <http://www.fhwa.dot.gov/map21/tap.cfm>

Chicago Metropolitan Agency for Planning, www.cmap.illinois.gov

Metra, <http://metraconnects.metrarail.com/star.php>

Pace, <http://www.pacebus.com/>

Pedestrian and Bicycle Information Center, www.bicyclinginfo.org

National Complete Streets Coalition, www.completestreets.org

FHWA Bicycle and Pedestrian Program, www.fhwa.dot.gov/environment/bikeped

Potential I-55 Improvements Study, <http://www.airportand126study.com/index.html>

Village of Plainfield Fiscal Year 2013-2014 Budget, <http://plainfield-il.org/>